

Shaping Tool holder

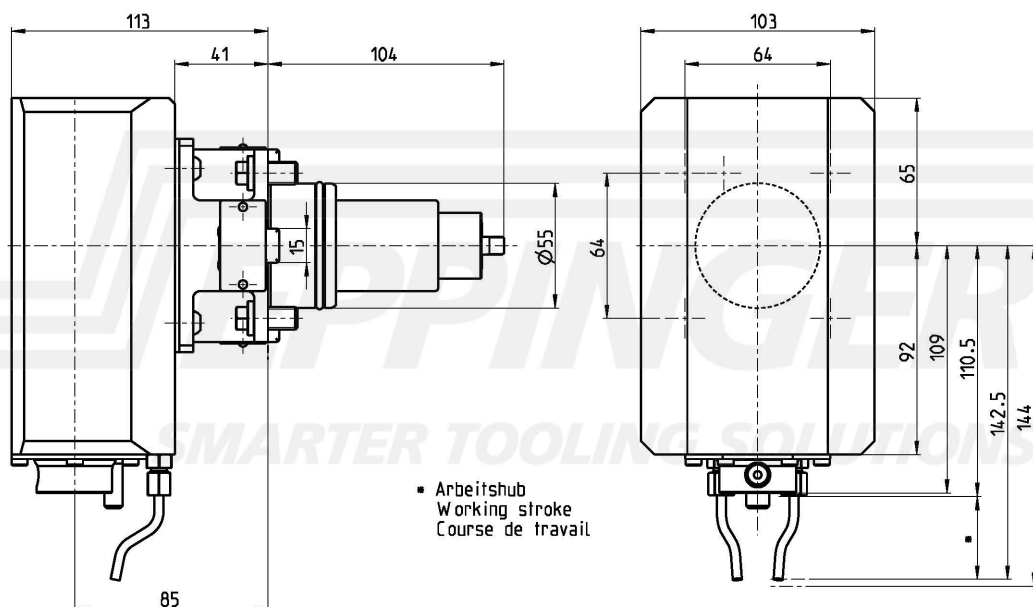

N. d'ordinazione 7.077.550

Rapp. di trasferimento 1:1
Velocità in entrata max. 1000 1/min
Velocità in uscita max. 1000 1/min
Coppia di uscita max. 25 Nm
Accessori For broaching tools Typ
SB105/SB110 und SH117
Paul Horn GmbH contact

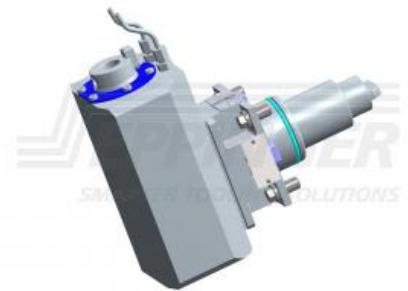

Salvo modifiche tecniche

01.08.2013 | 13.10.2014

ESA Eppinger GmbH | Breitwiesenweg 2-8 | 73770 Denkendorf, Germany | www.eppinger.de



Shaping Tool holder

N. d'ordinazione 7.077.815

Rapp. di trasferimento 1:1
Velocità in entrata max. 1000 1/min
Velocità in uscita max. 1000 1/min
Coppia di uscita max. 25 Nm
Accessori For broaching tools Typ
SB105/SB110 und SH117
Paul Horn GmbH contact

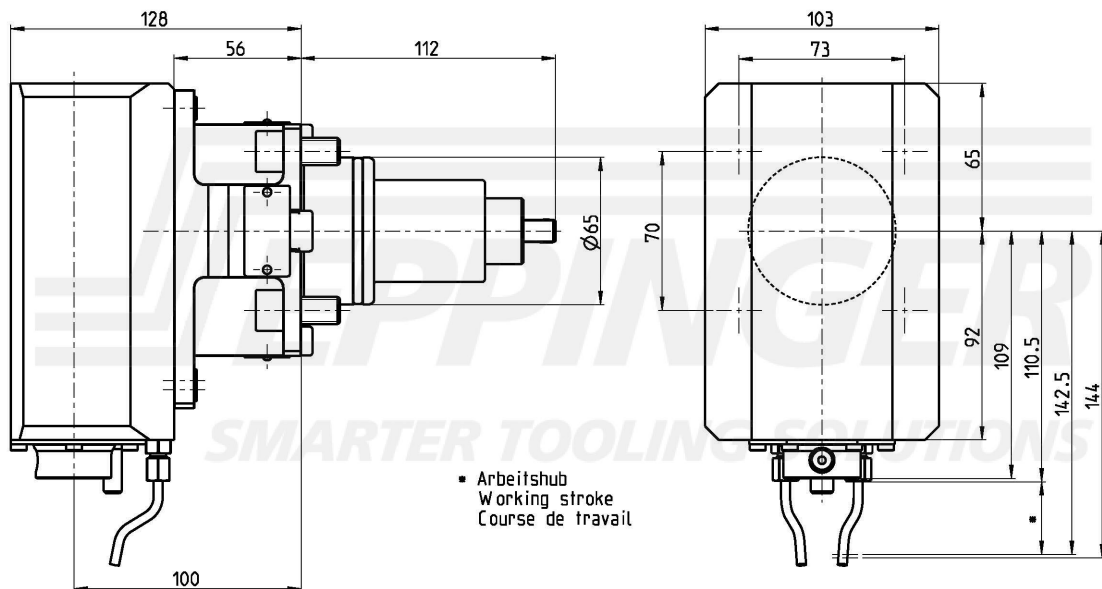
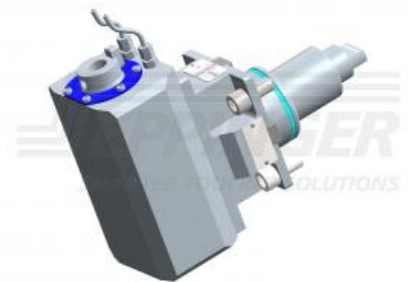

Salvo modifiche tecniche

04.11.2013 | 01.09.2016

ESA Eppinger GmbH | Breitwiesenweg 2-8 | 73770 Denkendorf, Germany | www.eppinger.de