

Ino·Grip Compact
3-Jaw Chuck

Ino·Grip Compact 3-Jaw Chuck

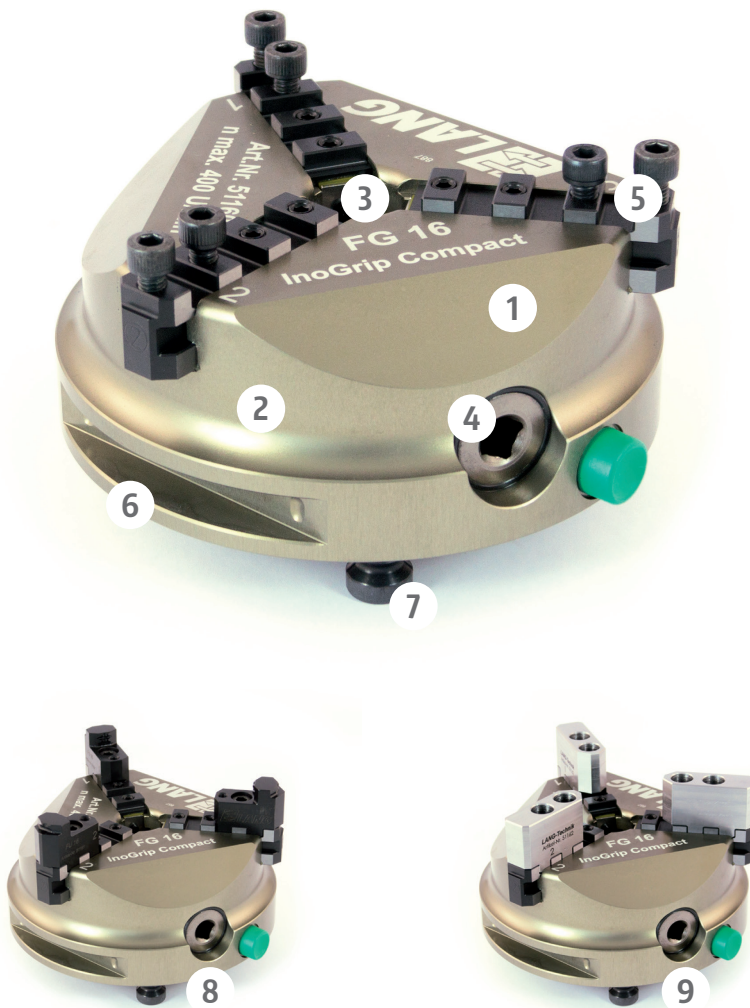

- ① Hand-operated scroll chuck
- ② Wear-resistant coated aluminium base body
- ③ Repeatability 0,06 mm (even better when jaws are milled under clamping pressure)
- ④ Square-headed actuation screw (11 mm)
- ⑤ 3 Base Jaws with cylinder head screws for assembly of hardened and soft top jaws
- ⑥ Ergonomic recessed grip, which can also be used as an automation interface
- ⑦ Equipped with 4 Clamping Studs for precise clamping in our Quick·Point® 96 Zero-Point System
- ⑧ 3-Jaw Chuck with hardened top jaws
- ⑨ 3-Jaw Chuck with soft top jaws

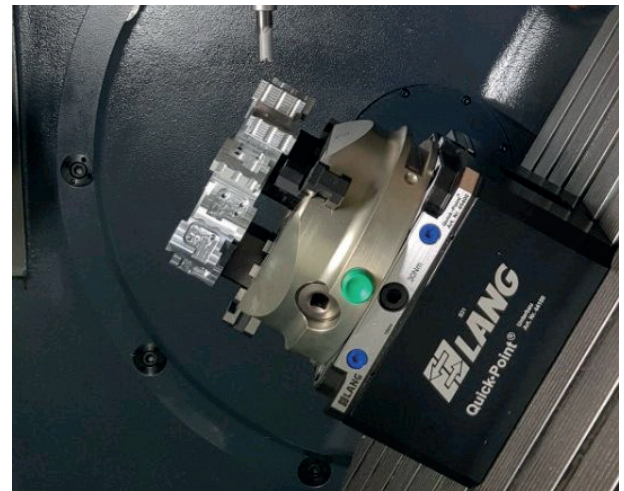
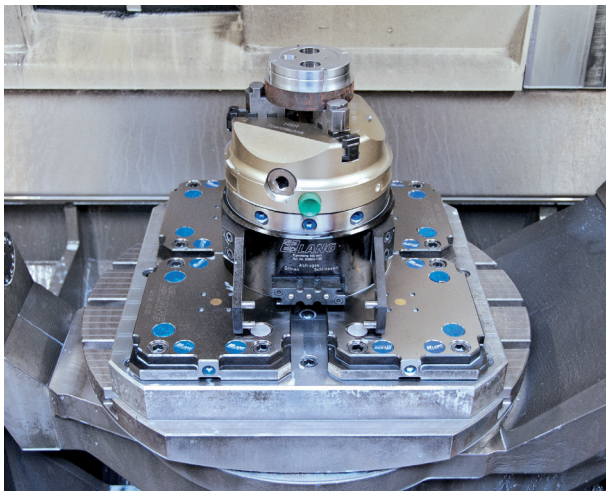

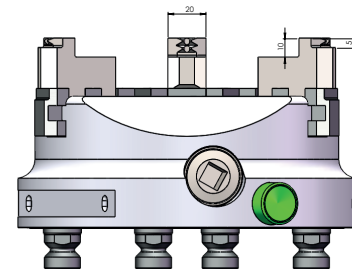
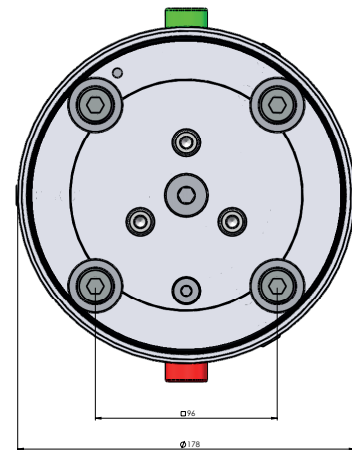
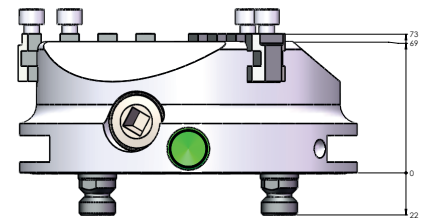

INO-GRIP COMPACT 3-JAW CHUCK

ITEM NO.	DIMENSIONS	WEIGHT
51160	Ø 178 x 73 mm	5.0 kg

INO-GRIP TOP JAWS, FU16, hardened (set of 3)

ITEM NO.	CLAMPING RANGE	WEIGHT
51161	30 - 160 mm	0.4 kg



INO-GRIP TOP JAWS, FI16, soft (set of 3)

ITEM NO.	CLAMPING RANGE	WEIGHT
51162	5 - 160 mm	0.7 kg





→ facebook.com/langtechnik
→ instagram.com/langtechnik

→ twitter.com/langtechnik
→ youtube.com/user/LangTechnik