

# Revolutionary High Speed Motors

*Constant Governed High Speed in 24/7 Operations*

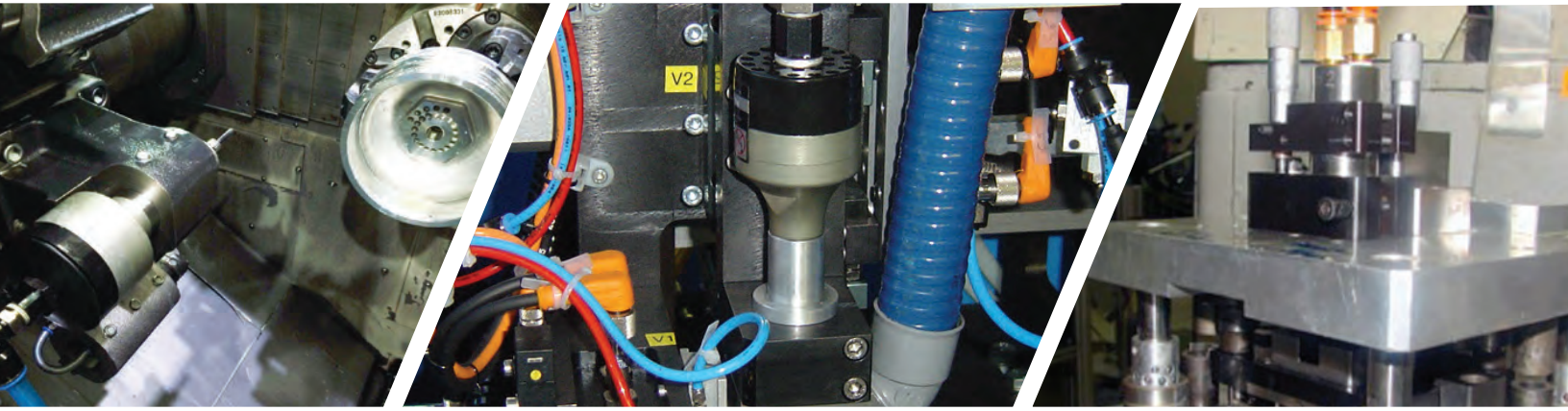

*Accelerate feed rates at  
25,000 - 65,000 rpm  
Power to 1.40 hp*

*Direct Drive Reliability  
Reduce Cycle Times*



# The Air Turbine Differences

**Our Constant Governed High Speed maintains high cutting speed - with no maintenance:**

**High Speeds: 25,000 to 65,000 rpm with as much power as you need: 0.15 - 1.40 hp (0.11 - 1.04 kW).**

- Our patented governor maintains constant high speed and torque under variable load on the tool path

## The Results:

- Faster feed rates dramatically accelerate production reducing costs.
- Improve finished surface quality.
- Optimize your cutting tool performance and life.
- 24/7 Operation, No Duty Cycle.

## Our Unique Low Friction Motor Saves Time and Money

- Our patented turbine drive has fewer moving parts, less heat, fewer repairs.
- Eliminate maintenance: direct drive motor with only 2 moving parts for superior reliability.
- Get the reliability of grease-packed bearings cooled by turbine air.
- Unlike other systems there are no vanes, gears or high frequency brushes to heat up and burn out.
- Simple to operate. No control system. No lubrication.

## Wide Applications in Automation and Robotics

- Accelerate feed rates in automated finishing, milling, drilling, swiss automatics and lathe applications.
- Robotic deburring, drilling, finishing and milling.
- Low vibration and weight make these Air Turbine Motors® ideal for robotic applications.

## Environmental Advantages

- Totally oil-free system: no mist and no part contamination.
- Quiet! Under 78 dBA.

## Technical

- Inlet air pressure 90 psi (6.2 bar). Dry clean air only.
- Up to 30% savings on compressed air consumption as a result of governor controlled airflow.
- Standard ER 8 / ER 11 collets included.
- 12 Month Limited Warranty / CE Mark. Collet Wrenches supplied with all motors.



# Select Your Motor - Basic Statistics for Matching Applications

## Motor Mount Specifications



Model	Mounting Barrel Outside Diameter	Vibration Magnitude	Power	Weight
<b>Light Powerful Aluminum Motors Series</b>				
202HD	19 mm	2.31 m/s <sup>2</sup> r.m.s	0.55 hp (0.41 kW)	9 oz (0.26 kg)
210HD	25 mm	0.34 m/s <sup>2</sup> r.m.s	0.88 hp (0.66 kW)	22 oz (0.62 kg)
450HD	41 mm	1.25 m/s <sup>2</sup> r.m.s	0.88 hp (0.66 kW)	46 oz (1.30 kg)
450HDE	41 mm	1.25 m/s <sup>2</sup> r.m.s	0.88 hp (0.66 kW)	48 oz (1.36 kg)
450XHD	41 mm	1.25 m/s <sup>2</sup> r.m.s	1.40 hp (1.04 kW)	48 oz (1.36 kg)
460HD	41 mm	1.25 m/s <sup>2</sup> r.m.s	0.94 hp (0.70 kW)	46 oz (1.30 kg)
<b>Sealed Steel Motors Series</b>				
720MX	20 mm	0.70 m/s <sup>2</sup> r.m.s	0.20 hp (0.15 kW)	13 oz (0.37 kg)
722MX	22 mm	0.70 m/s <sup>2</sup> r.m.s	0.20 hp (0.15 kW)	14 oz (0.40 kg)
725MX	25 mm	1.27 m/s <sup>2</sup> r.m.s	0.40 hp (0.30 kW)	22 oz (0.62 kg)
730MX	30 mm	1.00 m/s <sup>2</sup> r.m.s	0.20 hp (0.15 kW)	16 oz (0.45 kg)
732MX	32 mm	1.00 m/s <sup>2</sup> r.m.s	0.20 hp (0.15 kW)	18 oz (0.51 kg)
740MX	40 mm	0.36 m/s <sup>2</sup> r.m.s	0.40 hp (0.30 kW)	34 oz (0.96 kg)
740XP	40 mm	0.91 m/s <sup>2</sup> r.m.s	0.76 hp (0.57 kW)	58 oz (1.64 kg)

Just connect dry, clean 90 psi / 6.2 bar air supply. Accessory filter / extractor available.  
No Control System Needed. No Duty Cycle in 24/7 Operation.

# New Technology: End Maintenance and Frequent Repairs

Traditional motors require maintenance, frequent repairs, expensive part replacement and lubrication.

Electric high speed motors heat up and burn out.

*Air Turbine Motors®* are different.

Why?

**There are only two moving parts in *Air Turbine Motors®*:**

1. Proprietary governed turbines
2. Air cooled grease packed steel and ceramic bearings.



Our patented motors have low friction and great reliability.

**Governor Control**

1. Delivers Power on Demand
2. Minimizes Air Consumption



Patented Double Turbine Power  
to 1.40 hp (1.04 kW)

## What are the Differences between Vane, Electric Motors and Ungoverned Turbines?

- **Vanes and gears vibrate and burn out.**  
Vanes and gears vibrate and need frequent replacement. Thermal effects from heat in your motor prevent precision.
- **Most vane motors require lubrication.**  
Oil mist sprays on your work-piece. *Air Turbine Tools®* are oil-free. 
- **Using electric motors?**  
High Frequency brushes in electric motors create heat and burn up, necessitating repair. Most do not reach higher speeds. A control system is required with an expensive electrical box.
- **Ungoverned turbines quickly slow down when you are cutting and have low power.**  
Weak performance results in nominal high speed - dropping RPM's immediately when you start cutting operations. Ungoverned turbines don't have the high torque necessary to be effective in application and cut cycle times.
- ***Air Turbine Motors®* patented double turbines provide high torque - increasing airflow on demand - maintaining high speed on your toolpath.**

## Key Advantages at a Glance



**Governor Control for Constant High Torque.**  
Maintains High Speed + Power under Load.



**Direct Drive Reliability.**  
Only 2 Moving Parts.  
No Maintenance.



**Great Reliability.**  
Low Heat.  
No Control System.



**Operate 24/7.**  
No Duty Cycle.  
High Productivity.



**Governed Speed does not drop and maintains high speed on toolpath.**



**Faster Production.**  
Longer Tool Life.



**Low Vibration.**  
Quiet - Under 78 dBA.



**No Oil or Lubrication.**  
Just Supply 90 psi / 6.2 bar air.  
Environmentally Friendly.



**Improved Surface Quality.**  
Improved Accuracy.

# The Motors of a New Generation

## Constant High Speed and Power:

- Patented governed turbine maintains constant high speed under load.
- Accelerate production rates.
- Optimize cutting tool performance and life.
- Improve surface finish quality.



## High Precision:

- Low vibration and low heat improves precision.
- Precision ER 8 / ER 11 collets and h7 tolerance.

## Reliable:

- Only two moving parts (Turbine and Bearings).
- Air cooled grease packed bearings.
- No maintenance or lubrication.
- Low heat, no duty cycle in 24/7 operation.



**Shown: 740MX**  
0.40 hp - Governed 65,000 rpm.

**Multiple Options:**

- 202 Series  
Rubber Drilling
- 210 Series  
Robotics
- 450 Series  
Routing, Drilling, Deburring  
Heavy Duty, 1.40 hp (1.04 kW)
- 700 Series  
Automation  
Lathes + Swiss Automatics  
Completely Sealed
- 40 Motors available.

**Simple Setup:**

- Just connect dry, clean  
90 psi (6.2 bar) compressed air.

**Direct Drive Motor:**

- Double turbine power.
- No gears, high frequency brushes,  
or vanes to heat up or burn out.
- Low friction and heat. Long Service Life.
- No control system.

## 202HD Series

The popular long steel barrel **202HD** is a compact powerful fixture mount motor with governed constant speed ranges of 30,000, 40,000, 50,000 and 65,000 rpm. Ideal to drill rubber, plastic or mill faster and cleaner. Collet capacities of ER 8 1/8" (3mm) standard.

The **202HD** has a stainless steel barrel for rigid fixture mounting in plastic and rubber drilling and robotic metal finishing. Available on special order with double front bearings.

Oil free operation eliminates part contamination. High speed results in finer finished surfaces.

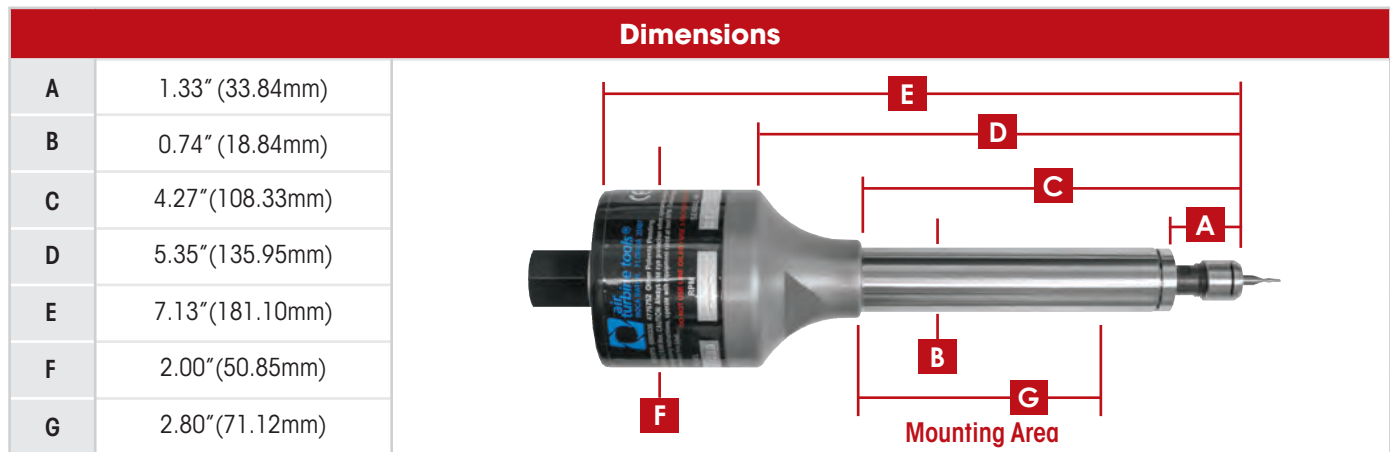

Part Numbers	30,000 rpm	40,000 rpm	50,000 rpm	65,000 rpm
Model	P/N	P/N	P/N	P/N
202HD ER 8 1/8"	32800	32802	32804	32806
202HD ER 8 3mm	32801	32803	32805	32807

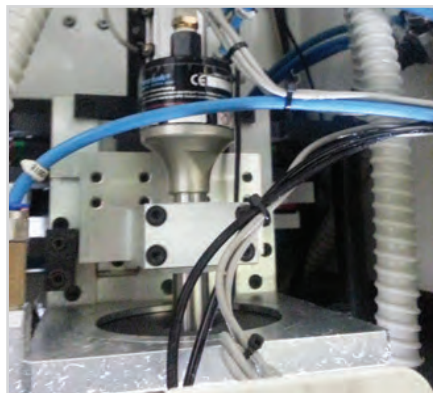

General Specifications	202HD
Governed Speed rpm	30,000 / 40,000 / 50,000 / 65,000
Power Rating hp (kW)	0.4 (.30) / 0.45 (.34) / 0.5 (.37) / 0.55 (.41)
Inlet Air Pressure (clean dry air only)	90 psi (6.2 bar)
Air Consumption Idle cfm (l/s)	10 (4.7) / 13 (6.1) / 14 (6.6) / 14 (6.6)
Air Consumption Working Flow cfm (l/s)	11 (5.19) - 20 (9.4)
Sound Level	Less Than 78 dBA
Max Shank Capacity	ER 8 - 1/8" (3mm)
Weight	9 oz (0.26 kg)

**Standard Equipment:** ER 8 1/8" or 3mm collet, collet wrenches, rear exhaust, and 1/4" NPT air supply fitting. Optional Collets and accessory filters are available. Optional ceramic and double bearing configurations available. **Use filter extractor #30008.**



# 210HD Series

The **210HD** motors with a 25mm outside diameter stainless steel barrel was developed for use where power is needed with a narrow motor barrel for reach. The **210HD** Series may be fixture mounted easily. The **210HD** has a precision ground stainless steel barrel for accurate mounted applications. Ideal for robotic finishing. For heavy duty applications see the 450HD.

The **210HD** Series delivers constant high speed for a cleaner cut and increased feed rates.

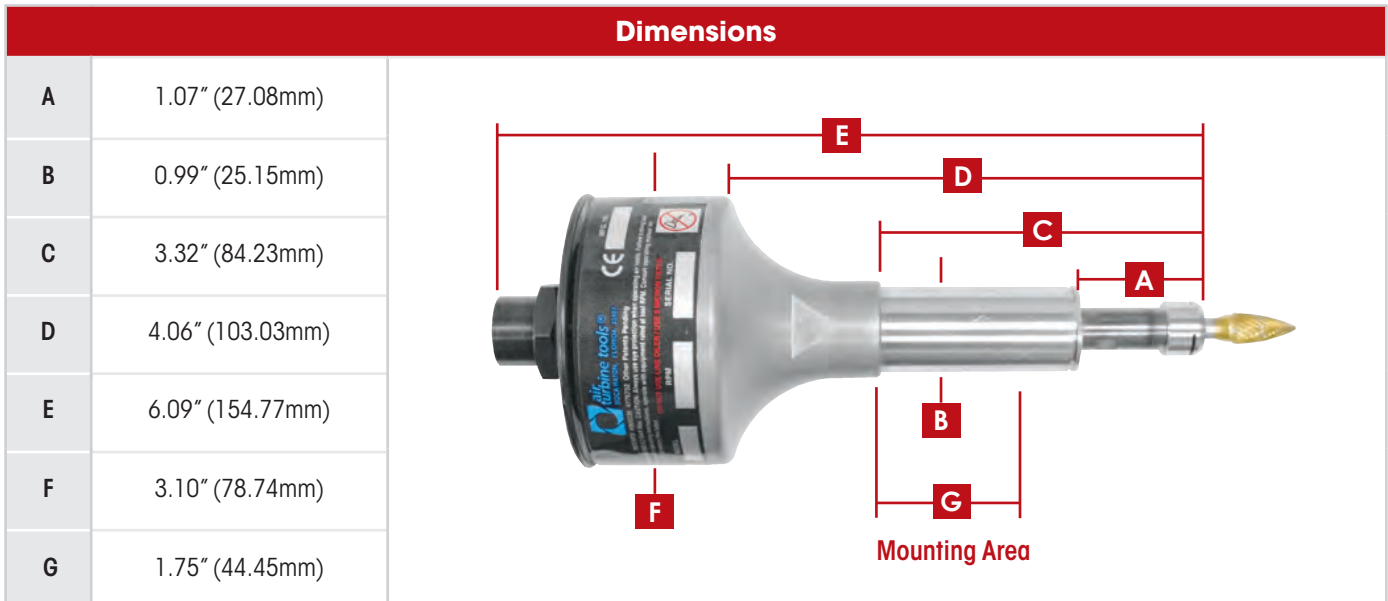

Part Numbers	30,000 rpm	40,000 rpm
Model	P/N	P/N
210HD ER 11 1/4"	32452	32454
210HD ER 11 6mm	32453	32455

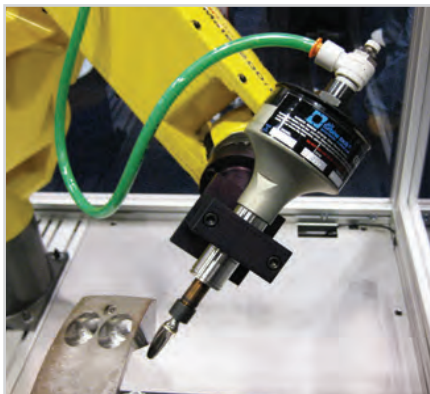

General Specifications	210HD
Governed Speed rpm	30,000 / 40,000
Power Rating hp (kW)	0.83 (0.62) / 0.88 (0.66)
Inlet Air Pressure (clean dry air only)	90 psi (6.2 bar)
Air Consumption Idle cfm (l/s)	14 (6.6) / 14 (6.6)
Air Consumption Working Flow cfm (l/s)	14 (6.61) - 35 (16.52)
Sound Level	Less Than 78 dBA
Max Shank Capacity	ER 11 - 1/4" (6mm)
Weight	22 oz (0.62 kg)

**Standard Equipment:** ER 11 1/4" or 6mm collet, collet wrenches, rear exhaust and 3/8" NPT air supply fitting. Optional Collets and accessory filters are available. **Use filter extractor #30008.**

# 450HD Series

Ceramic bearings, an ER 11 collet, and a rigid steel barrel for mounting make the **450HD** ideal for cutting or finishing harder materials. Sealed at front end for wet environments. Our durable direct drive governed motor makes this unit a reliable workhorse.

Powerful 24/7 performance with 0.88 hp (0.66 kW) at governed 40,000 rpm.

Very low vibration magnitude of 1.25 m/s<sup>2</sup> r.m.s, makes the well balanced **450HD** ideal for robotic integration. Rigid barrel for mounting. Frequent applications include finishing, drilling, milling and routing.

Dimensions	
A	1.05" (26.54mm)
B	1.62" (41.15mm)
C	5.20" (86.15mm)
D	6.03" (153.16mm)
E	7.61" (193.29mm)
F	3.10" (78.74mm)
G	2.80" (71.12mm)

Part Numbers	25,000 rpm	30,000 rpm	40,000 rpm
Model	P/N	P/N	P/N
450HD ER 11 1/4"	34450	34452	34454
450HD ER 11 6mm	34451	34453	34455

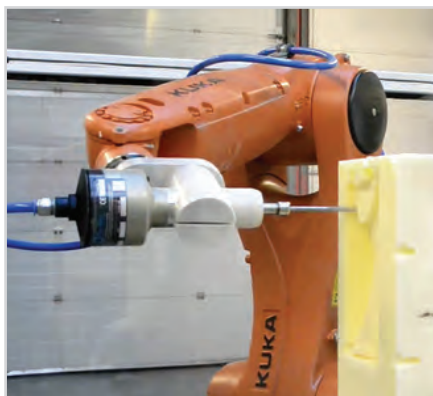

General Specifications	450HD
Governed Speed rpm	25,000 / 30,000 / 40,000
Power Rating hp (kW)	0.76 (0.57) / 0.83 (0.62) / 0.88 (0.66)
Inlet Air Pressure (clean dry air only)	90 psi (6.2 bar)
Air Consumption Idle cfm (l/s)	13 (6.1) / 14 (6.6) / 14 (6.6)
Air Consumption Working Flow cfm (l/s)	14 (6.61) - 35 (16.52)
Sound Level	Less Than 78 dBA
Max Shank Capacity	ER 11 - 1/4" (6mm)
Weight	46 oz (1.30 kg)

**Standard Equipment:** Coolant guard, ER 11 1/4" or 6mm collet, collet wrenches, rear exhaust and 3/8" NPT air supply fitting. Optional Collets and accessory filters are available. **Use filter extractor #30008.**

# 450HDE Series

The new **450HDE** reaches into pockets and angles, ideal for cutting or finishing hard to reach work areas. The **450HDE**'s sealed front-end prevents wet or dust contamination from getting inside the motor.

This patented single turbine motor operates at governed speeds of 25,000, 30,000 or 40,000 rpm with power to 0.88 hp (0.66 kW). Ideal for routing composites, plastics or wood and deburring, finishing or drilling metal at constant high speed.

The rigid 41 mm O.D. steel barrel is easily fixtured for automation or combined with an end effector.

Dimensions	
A	2.88" (73.15mm)
B	1.62" (41.15mm)
C	6.88" (174.75mm)
D	7.88" (200.15mm)
E	9.63" (244.60mm)
F	3.10" (78.74mm)
G	2.80" (71.12mm)

Part Numbers	25,000 rpm	30,000 rpm	40,000 rpm
Model	P/N	P/N	P/N
450HDE ER 11 1/4"	34480	34482	34484
450HDE ER 11 6mm	34481	34483	34485



General Specifications	450HDE
Governed Speed rpm	25,000 / 30,000 / 40,000
Power Rating hp (kW)	0.76 (0.57) / 0.83 (0.62) / 0.88 (0.66)
Inlet Air Pressure (clean dry air only)	90 psi (6.2 bar)
Air Consumption Idle cfm (l/s)	13 (6.1) / 14 (6.6) / 14 (6.6)
Air Consumption Working Flow cfm (l/s)	14 (6.61) - 35 (16.52)
Sound Level	Less Than 78 dBA
Max Shank Capacity	ER 11 - 1/4" (6mm)
Weight	48 oz (1.36 kg)

**Standard Equipment:** Coolant guard, ER 11 1/4" or 6mm collet, collet wrenches, rear exhaust and 3/8" NPT air supply fitting. Optional Collets and accessory filters are available. **Use filter extractor #30008.**

# 450XHD Series

When hard material is being cut select the powerful **450XHD**. This motor's double front and double rear ceramic bearings assure durability in 24 hour operations. The **450XHD**'s sealed front-end prevents wet or dust contamination from getting inside the motor.

This patented double turbine motor operates at governed speeds of 25,000, 30,000 or 40,000 rpm with power to 1.4 hp (1.04 kW). Ideal for routing composites, plastics or wood and deburring, finishing or drilling metal at constant high governed speed. The rigid 41mm outside diameter steel barrel is easily fixtured for automation or combined with an end effector.

Dimensions	
A	1.05" (26.54mm)
B	1.62" (41.15mm)
C	5.20" (86.15mm)
D	6.03" (153.16mm)
E	8.07" (204.97mm)
F	3.10" (78.74mm)
G	2.80" (71.12mm)

Part Numbers	25,000 rpm	30,000 rpm	40,000 rpm
Model	P/N	P/N	P/N
450XHD ER 11 1/4"	34456	34458	34460
450XHD ER 11 6mm	34457	34459	34461



General Specifications	450XHD
Governed Speed rpm	25,000 / 30,000 / 40,000
Power Rating hp (kW)	1.2 (.90) / 1.3 (.98) / 1.4 (1.04)
Inlet Air Pressure (clean dry air only)	90 psi (6.2 bar)
Air Consumption Idle cfm (l/s)	25 (11.80)
Air Consumption Working Flow cfm (l/s)	26 (12.27) - 50 (23.60)
Sound Level	Less Than 78 dBA
Max Shank Capacity	ER 11 - 1/4" (6mm)
Weight	48 oz (1.36 kg)

**Standard Equipment:** Coolant guard, ER 11 1/4" or 6mm collet, collet wrenches, rear exhaust and 3/8" NPT air supply fitting. Optional Collets and accessory filters are available. **Use filter extractor #30084.**

## 460HD Series - 50,000 rpm

The governed 50,000 rpm, 0.94 hp (0.70 kW), has a rigid steel barrel for mounting make the new governed **460HD** ideal for cutting or finishing harder materials. Sealed at the front end for wet environments. The 460's durable, direct drive, low heat and low vibration governed motor is a reliable workhorse with powerful performance 24/7.

A low vibration magnitude of 1.25 m/s<sup>2</sup> r.m.s, makes the well balanced **460HD** ideal for robotic integration. Applications include finishing, drilling, milling and routing.

Dimensions	
A	1.05" (26.54mm)
B	1.62" (41.15mm)
C	5.20" (86.15mm)
D	6.03" (153.16mm)
E	7.61" (193.29mm)
F	3.10" (78.74mm)
G	2.80" (71.12mm)

Part Numbers	50,000 rpm
Model	P/N
460HD ER 11 1/4"	34470
460HD ER 11 6mm	34471



General Specifications	460HD
Governed Speed rpm	50,000
Power Rating hp (kW)	0.91 (0.68)
Inlet Air Pressure (clean dry air only)	90 psi (6.2 bar)
Air Consumption Idle cfm (l/s)	14 (6.61)
Air Consumption Working Flow cfm (l/s)	14 (6.61) - 35 (16.52)
Sound Level	Less Than 78 dBA
Max Shank Capacity	ER 11 - 1/4" (6mm)
Weight	46 oz (1.30 kg)

**Standard Equipment:** Coolant guard, ER 11 1/4" or 6mm collet, collet wrenches, rear exhaust and 3/8" NPT air supply fitting. Optional Collets and accessory filters are available. **Use filter extractor #30008.**

# 720MX Series

The **720MX** retrofits swiss automatics. This compact low vibration motor operates 24/7 with low heat and has just 2 moving parts and no gears, vanes, or high frequency brushes to burn up.

Drop in the **720MX** to accelerate your production and increase your productivity. For use with micro tools.

Ideal for lathes, swiss automatics and finishing with micro tools. No control system or maintenance.

**Mountable area of 20mm by 90mm.** Completely sealed with hose exhausts.

Dimensions	
A	0.82" (20.83mm)
B	0.79" (20.00mm)
C	3.94" (100.08mm)
D	3.56" (90.46mm)
E	7.07" (179.58mm)
F	1.18" (30.00mm)

Part Numbers	50,000 rpm	65,000 rpm
Model	P/N	P/N
720MX ER 8 1/8"	70132	70134
720MX ER 8 3mm	70133	70135

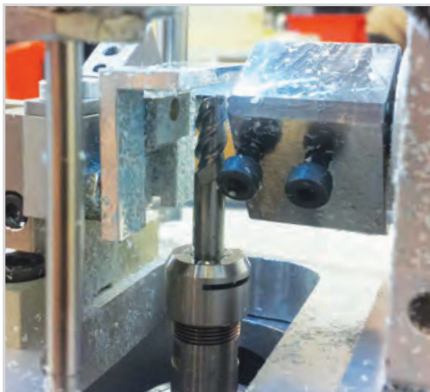

General Specifications	720MX
Governed Speed rpm	50,000 / 65,000
Power Rating hp (kW)	0.20 (0.15) / 0.20 (0.15)
Inlet Air Pressure (clean dry air only)	90 psi (6.2 bar)
Air Consumption Idle cfm (l/s)	4 (1.88) / 4 (1.88)
Air Consumption Working Flow cfm (l/s)	6 (2.83) - 9 (4.24)
Sound Level	Less Than 78 dBA
Max Shank Capacity	ER 8 - 1/8" (3mm)
Weight	13 oz (0.37 kg)

**Standard Equipment:** ER 8 1/8" or 3mm collet, collet wrenches and 1/8" air supply and exhaust fitting. Optional Collets and accessory filters are available. **Use filter extractor #30008.**

# 722MX Series

The patented double turbine **722MX** generates 0.20 hp to keep high speed under load. This is a low vibration motor with just 2 moving parts, no gears, vanes, or high frequency brushes to burn up.

Mount the **722MX** to accelerate your production and cut your repair costs and downtime.

Ideal for lathes, swiss automatics and finishing. For use with micro tools.

**Mountable area of 22mm by 90mm.** Completely sealed with hose exhausts.

Dimensions	
A	0.82" (20.83mm)
B	0.87" (22.00mm)
C	3.94" (100.08mm)
D	3.56" (90.46mm)
E	7.07" (179.58mm)
F	1.18" (30.00mm)

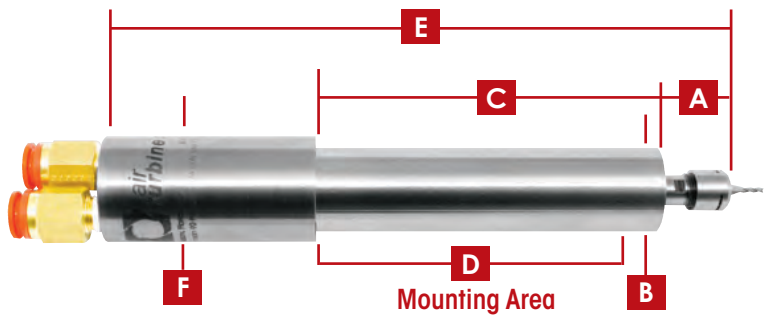

Part Numbers	50,000 rpm	65,000 rpm
Model	P/N	P/N
722MX ER 8 1/8"	70074	70078
722MX ER 8 3mm	70075	70079



General Specifications	722MX
Governed Speed rpm	50,000 / 65,000
Power Rating hp (kW)	0.20 (0.15) / 0.20 (0.15)
Inlet Air Pressure (clean dry air only)	90 psi (6.2 bar)
Air Consumption Idle cfm (l/s)	4 (1.88) / 4 (1.88)
Air Consumption Working Flow cfm (l/s)	6 (2.83) - 9 (4.24)
Sound Level	Less Than 78 dBA
Max Shank Capacity	ER 8 - 1/8" (3mm)
Weight	14 oz (0.40 kg)

**Standard Equipment:** ER 8 1/8" or 3mm collet, collet wrenches and 1/8" air supply and exhaust fitting. Optional Collets and accessory filters are available. **Use filter extractor #30008.**

# 725MX Series

Despite its 25mm outside diameter, the **725MX** has 0.40 hp to maintain your cutting tool's high rotational speed at 40,000 or 50,000 rpm. The higher production rates you achieve with the **725MX** will surprise you.

Air Turbine Motors® patented double direct drive in the **725MX** does not get hot or vibrate. Air cools the sealed grease packed bearings. The result is durability in 24/7 operation with no maintenance and no control system.

**Mountable area of 25mm by 39mm.** Completely sealed with hose exhausts. ER 11 1/4" / 6mm collet capacity.

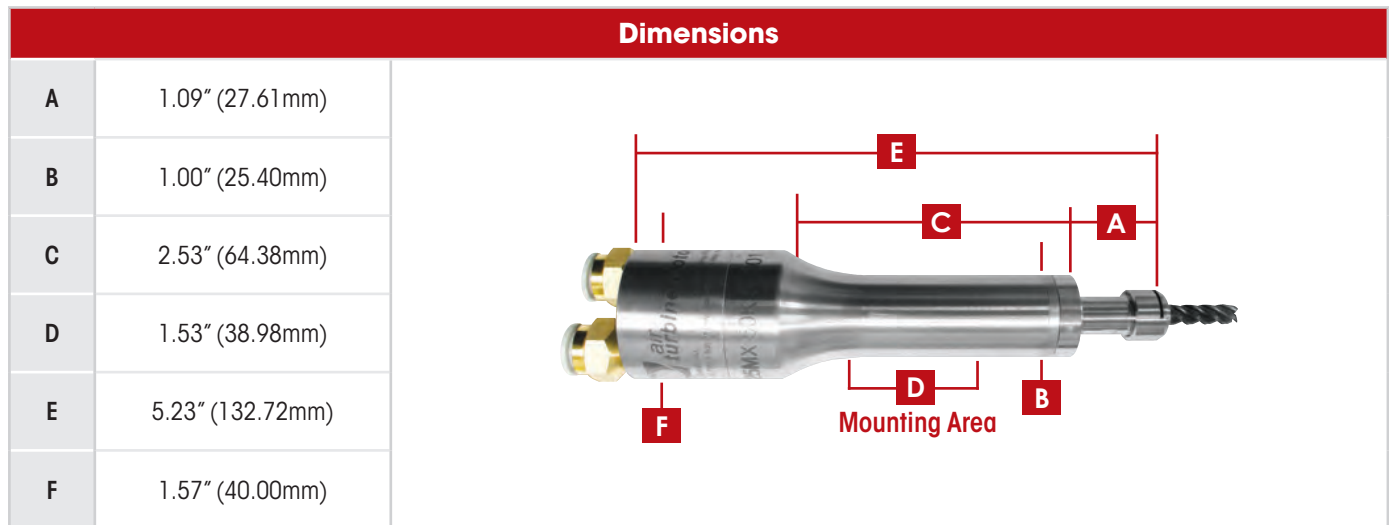

Part Numbers	40,000 rpm	50,000 rpm
Model	P/N	P/N
725MX ER 11 1/4"	70150	70152
725MX ER 11 6mm	70151	70153



General Specifications	725MX
Governed Speed rpm	40,000 / 50,000
Power Rating hp (kW)	0.30 (0.22) / 0.40 (0.30)
Inlet Air Pressure (clean dry air only)	90 psi (6.2 bar)
Air Consumption Idle cfm (l/s)	5 (2.36) / 6 (2.83)
Air Consumption Working Flow cfm (l/s)	7 (3.30) - 10 (4.72)
Sound Level	Less Than 78 dBA
Max Shank Capacity	ER 11 - 1/4" (6mm)
Weight	22 oz (0.62 kg)

**Standard Equipment:** ER 11 1/4" or 6mm collet, collet wrenches and 1/4" air supply and exhaust fitting. Optional Collets and accessory filters are available. **Use filter extractor #30008.**



# 730MX Series

The popular **730MX** is ideal for lab mills, lathes, and all fixture or robotic applications. Reach deep and run faster for accelerated production and cleaner cutting action. Get finer finished surfaces with faster cycle times.

Lower vibration and greater reliability result from fewer moving parts in this direct drive, oil free geared double turbine motor.

**Mountable area of 30mm by 95mm.** Completely sealed with hose exhausts.

Dimensions	
A	0.91" (23.03mm)
B	1.18" (30.00mm)
C	4.34" (110.35mm)
D	3.74" (95.11mm)
E	5.25" (133.35mm)

Part Numbers	50,000 rpm	65,000 rpm
Model	P/N	P/N
730MX ER 8 1/8"	70004	70008
730MX ER 8 3mm	70005	70009



General Specifications	730MX
Governed Speed rpm	50,000 / 65,000
Power Rating hp (kW)	0.20 (0.15) / 0.20 (0.15)
Inlet Air Pressure (clean dry air only)	90 PSI (6.2 Bar)
Air Consumption Idle cfm (l/s)	4 (1.88) / 4 (1.88)
Air Consumption Working Flow cfm (l/s)	6 (2.83) - 9 (4.24)
Sound Level	Less Than 78 dBA
Max Shank Capacity	ER 8 - 1/8" (3mm)
Weight	16 oz (0.45 kg)

**Standard Equipment:** ER 8 1/8" or 3mm collet, collet wrenches and 1/8" air supply and exhaust fitting. Optional Collets and accessory filters are available. **Use filter extractor #30008.**

# 732MX Series

The **732MX** Series drops into lab mills, lathes, swiss automatics and all fixture and robotic applications. Constant governed high speed delivers faster cycle times and a finer finished surface.

Lower vibration results from fewer moving parts in this direct drive, double turbine powered motor. Turbine air circulates to cool the ceramic bearings resulting in great reliability.

**Mountable area of 32mm by 95mm.** Completely sealed with hose exhausts.

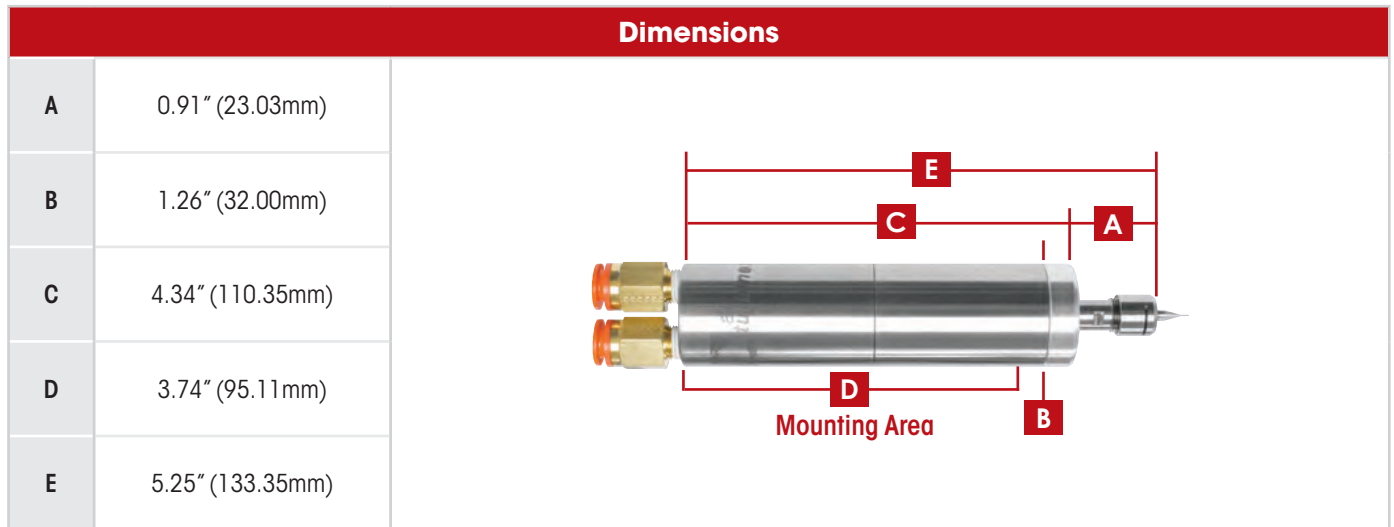

Part Numbers	50,000 rpm	65,000 rpm
Model	P/N	P/N
732MX ER 8 1/8"	70104	70108
732MX ER 8 3mm	70105	70109

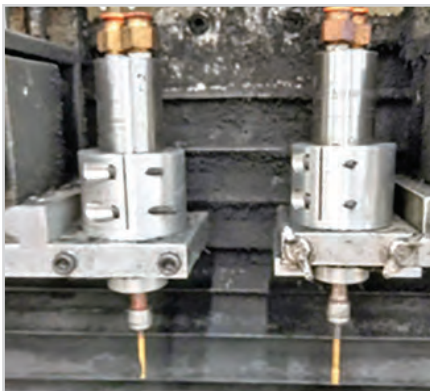

General Specifications	732MX
Governed Speed rpm	50,000 / 65,000
Power Rating hp (kW)	0.20 (0.15) / 0.20 (0.15)
Inlet Air Pressure (clean dry air only)	90 PSI (6.2 Bar)
Air Consumption Idle cfm (l/s)	4 (1.88) / 4 (1.88)
Air Consumption Working Flow cfm (l/s)	6 (2.83) - 9 (4.24)
Sound Level	Less Than 78 dBA
Max Shank Capacity	ER 8 - 1/8" (3mm)
Weight	18 oz (0.51 kg)

**Standard Equipment:** ER 8 1/8" or 3mm collet, collet wrenches and 1/8" air supply and exhaust fitting. Optional Collets and accessory filters are available. **Use filter extractor #30008.**

# 740MX Series

The powerful **740MX** is a lightweight motor with power to maintain high speed on your tool path. The direct drive turbine permits operations 24/7 with great durability. The rigid steel housing enables you to mount anywhere and is sealed for contaminated environments.

Get governed high speed under load, not speeds that drop when your tool starts cutting. Eliminate lubrication, vanes, gears and brushes and accelerate your production rate.

**Mountable area of 40mm by 152mm.** Completely sealed with hose exhausts.

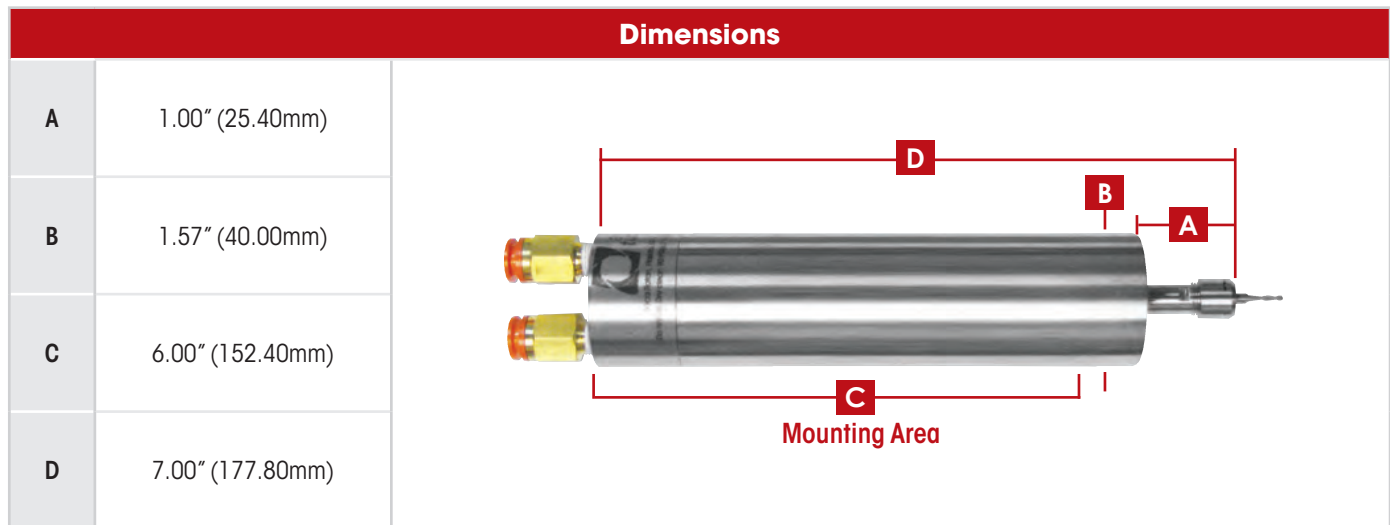

Part Numbers	40,000 rpm	50,000 rpm	65,000 rpm
Model	P/N	P/N	P/N
740MX ER 11 1/4"	70114	70118	70122
740MX ER 11 6mm	70115	70119	70123



General Specifications	740MX
Governed Speed rpm	40,000 / 50,000 / 65,000
Power Rating hp (kW)	0.3 (0.22) / 0.3 (0.22) / 0.4 (0.30)
Inlet Air Pressure (clean dry air only)	90 PSI (6.2 Bar)
Air Consumption Idle cfm (l/s)	5 (2.63) / 6 (2.83) / 6 (2.83)
Air Consumption Working Flow cfm (l/s)	7 (3.30) - 10 (4.72)
Sound Level	Less Than 78 dBA
Max Shank Capacity	ER 11 - 1/4" (6mm)
Weight	34 oz (0.96 kg)

**Standard Equipment:** ER 11 1/4" or 6mm collet, collet wrenches and 1/8" air supply and exhaust fitting. Optional Collets and accessory filters are available. **Use filter extractor #30008.**

# 740XP Series

Suitable for heavier applications, the patented double turbine **740XP** generates 0.76 hp and 50,000 rpm. The **740XP's** governor keeps your speed high under load. This is a low vibration motor with just 2 moving parts and air cooled ceramic bearings for reliable operation 24/7. Versatile - for finishing, milling and drilling.

Accelerate your production and cut your repair costs and downtime. Eliminate control systems and maintenance. Ideal for lathes, swiss automatics, robotics and finishing.

**Mountable area of 40mm by 82mm.** Completely sealed with hose exhausts.

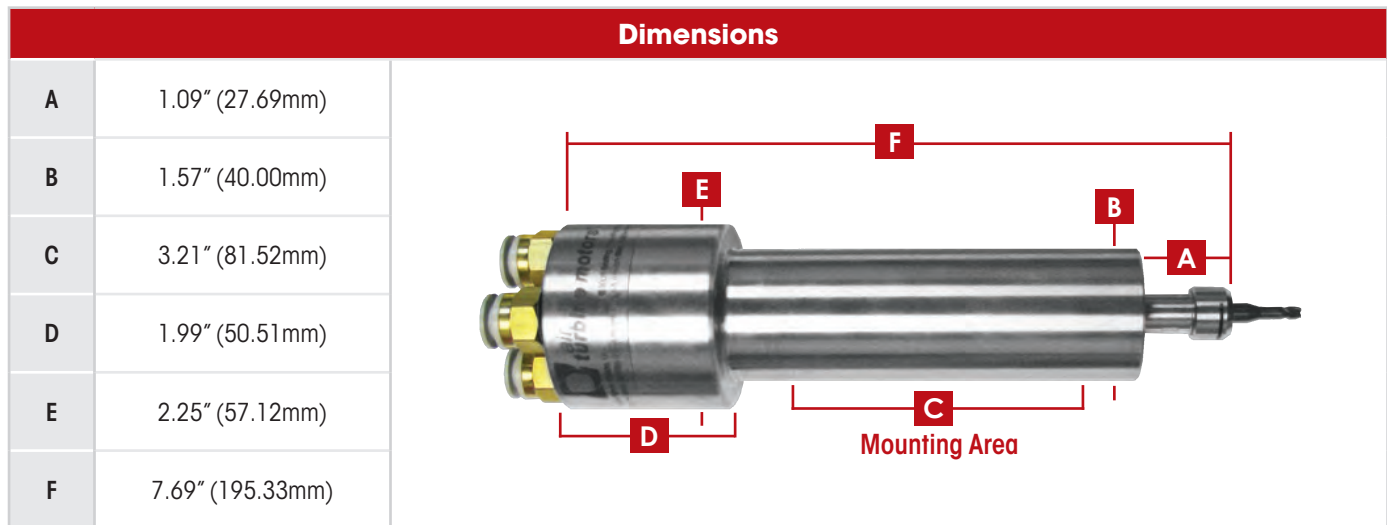

Part Numbers	30,000 rpm	40,000 rpm	50,000 rpm
Model	P/N	P/N	P/N
740XP ER 11 1/4"	70052	70054	70056
740XP ER 11 6mm	70053	70055	70057

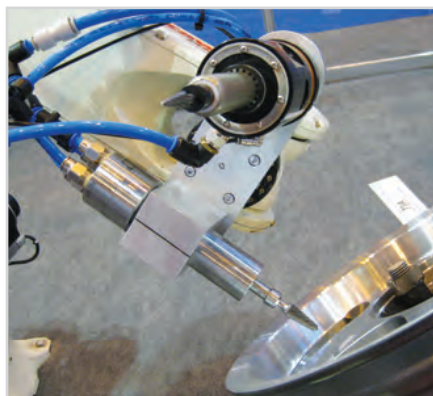

General Specifications	740XP
Governed Speed rpm	30,000 / 40,000 / 50,000
Power Rating hp (kW)	0.72 (0.54) / 0.74 (0.55) / 0.76 (0.57)
Inlet Air Pressure (clean dry air only)	90 PSI (6.2 Bar)
Air Consumption Idle cfm (l/s)	16 (7.55) / 20 (9.44) / 20 (9.44)
Air Consumption Working Flow cfm (l/s)	17 (8.02) - 45 (21.2)
Sound Level	Less Than 78 dBA
Max Shank Capacity	ER 11 - 1/4" (6mm)
Weight	58 oz (1.64 kg)

**Standard Equipment:** ER 11 1/4" or 6mm collet, collet wrenches and 3/8" air supply and exhaust fitting. Optional Collets and accessory filters are available. **Use filter extractor #30008.**

# Accessories

ER 8 Optional Sized Nut & Collets Models 202, 720, 722, 730, 732	
P/N	Description
10953	COLLET 0.50mm
10954	COLLET 1/8"
10955	COLLET 1/16"
10956	COLLET 3/16"
10957	COLLET 1mm
10958	COLLET 1.50mm
10959	COLLET 2mm
10960	COLLET 2.50mm
10961	COLLET 3mm
10962	COLLET 3.50mm
10963	COLLET 4mm
10964	COLLET 4.50mm
10968	COLLET NUT
10967	WRENCH (ER 8)
12677	WRENCH (5/16")

ER 11 Optional Sized Nut & Collets Models 450, 460, 725, 740MX, 740XP	
P/N	Description
11040	COLLET 1mm
11041	COLLET 1.5mm
11042	COLLET 1/16"
11043	COLLET 2mm
11044	COLLET 2.5mm
11045	COLLET 3mm
11046	COLLET 1/8"
11047	COLLET 3.5mm
11048	COLLET 4mm
11049	COLLET 4.5mm
11050	COLLET 3/16"
11051	COLLET 5mm
11052	COLLET 5.5mm
11053	COLLET 6mm
11054	COLLET 1/4"
11055	COLLET 6.5mm
11056	COLLET 7mm
11057	COLLET NUT - Rego-Fix
11058	WRENCH (ER 11)
12473	WRENCH (7/16")

Filters / Extractors	
Part #30085	
P/N	Description
30084	High Flow Filter Regulator Extractor with 1/2" NPT (use for 450X models) 0.3 µm
30008	High Flow Filter Regulator Extractor (use for all models except 450X) 0.3 µm

# Installation Kits



## Solenoid Assembly for 720, 722, 725, 730, 732, 740MX, 202 Units

120V Part #30027 • 240V Part #30076

Qty	Description
1	Hose 12mm OD - 12' (3.66m)
1	Hose 10mm OD - 13' (3.96m)
1	12mm - 3/8" Unifit Fitting
1	10mm - 3/8" Unifit Fitting
1	10mm 1/8" Unifit Fitting
1	Solenoid 120V or 240V

## Solenoid Assembly for 210, 450, 460, 740XP Units

120V Part #30029 • 240V Part #30078

Qty	Description
1	Hose 12mm OD - 25' (7.62m)
1	12mm - 3/8" Unifit Fitting
1	Solenoid 120V or 240V

## Solenoid Assembly for 450X Units

120V Part #30086 • 240V Part #30087

Qty	Description
1	Hose 16mm OD - 25' (7.62m)
1	16mm - 1/2" Unifit Fitting
1	Solenoid 120V or 240V

## Manual Shut-Off Valve Installation Kit for all units except for 450X Units

Part #30079

Qty	Description
1	Shut-off Valve Assembly
1	25' Hose 12mm OD
3	Quick Change Unifit Connectors 3/8"

## Manual Shut-Off Valve Installation Kit for 450X Units

Part #30085

Qty	Description
1	Shut-off Valve Assembly
1	25' Hose 16mm OD
3	Quick Change Unifit Connectors 1/2"

## User Notes

1. Turn off air before installing your motor or cutting tool. See notes on each catalog page regarding unrestricted, clean air supply and minimum internal dimensions of hoses, couplings and connectors. Use dry clean unrestricted air supply at 90 psi / 6.2 bar pressure. Contamination will damage your turbine so please use accessory filters. Select a small size, speed rated cutting tool capable of evacuating chips at high speed.
2. Mount fixtures on indicated area (steel sleeve on aluminum 202HD or 400HD motors) and not over bearings. Angular contact bearings available for drilling applications on some units.
3. If drilling rubber band stop the band completely before the motor descends to drill.
4. Outside Diameter Tolerance on 700 Series is h7 tolerance ( 0 / - 21 $\mu$ m ). 700 Series units are sealed with hose exhaust and suitable for lathe use / swiss automatic fixturing.
5. If your motor vibrates, is hot or makes a loud noise, disconnect and send for authorized distributor or factory service.
6. Install exhaust hose(s) on 700 Series to avoid contamination entering your motor and to meet dBA specifications.
7. Restriction of air flow by small hoses and couplings will cause underpowered performance. Sudden drops of air supply will damage bearings, so please check your compressor capacity and flow rate cfm / l/s.

### General Notes:

The following are abbreviated extracts from safety procedures. Read and comply with all applicable regulations.

- Prior to inserting any cutting tool, check the RPM with a tachometer to ensure that the actual speed does not exceed the rated speed. This check should be performed at least once every 20 hours of use, or once weekly, whichever is more frequent.
- Always use OSHA approved eye and face protection.
- Check to make sure the collet is fully tightened. Use wrenches provided.
- Air pressure supplied must not exceed 100 psi (7.2 bar) or be less than 90 psi (6.2 bar). Check cfm / l/s air flow rate is at least the recommended minimum.
- Use only concentric speed rated cutting tools. If tool vibrates, do not use it.
- Only operate tool in a protected area.
- If unused for more than six months it is recommended to operate the motor for at least five minutes to avoid bearing grease deterioration.
- Ensure airlines are clean and of the minimum diameter specified for your motor.

**Use good judgment. Remember, this is a powerful tool. Use with caution.**

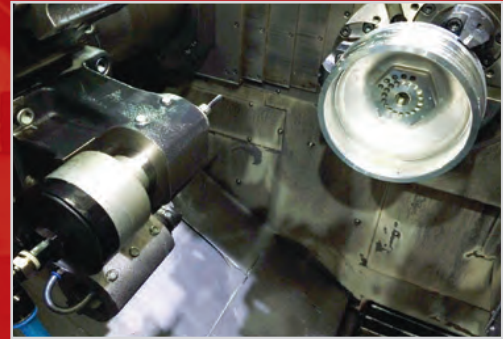
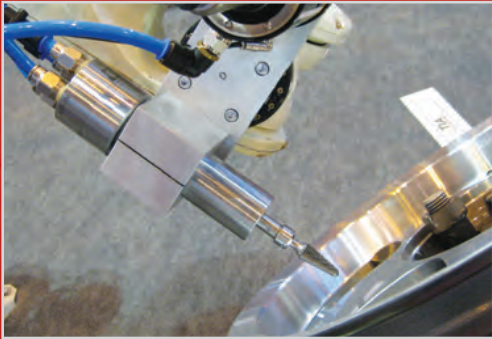

**High Speed Spindle Series**



**Distributor**



1225 Broken Sound Parkway, NW, Suite. D • Boca Raton, Florida 33487, USA

Phone: +1.561.994.0500 • Fax: +1.561.994.8097 • info@airturbinetools.com • www.airturbinetools.com

Use couplings / hoses with a minimum ID of 5mm for 720, 722, 730 and 732 motors, a minimum ID of 1/4" / 6mm for 202 motors, a minimum ID of 6.5mm for 725MX and 740MX motors, a minimum ID of 8mm for 450, 460 and 740XP motors, a minimum ID of 3/8" / 9.5mm for 210 motors and a minimum ID of 10mm for 450X and 460X motors. Always use a 0.3 micron filter and/or extractor where required and check specified psi or l/s air flow. Use 90 psi / 6.2 Bar clean, dry, oil-free air only. Use eye protection and follow safety instructions. Supply is subject to Air Turbine Tools Inc, terms and conditions of sale and distributor policies in effect for the time being. Subject to availability, change of specifications, price and terms without notice. All specifications approximate.

Air Turbine Motors® is the registered trade name of Air Turbine Tools, Inc. © 2018 Air Turbine Tools, Inc. All rights reserved.