



# Live Centers / Dead Centers

**Centers for turning  
and grinding applications**

- Live Centers
- Dead Centers
- Dead Centers with Carbide Insert
- Accessories
- Special Centers



# Ultra Live Center RN

## Clamping tools for clamping on machine tools

NEIDLEIN ultra live centers are designed for employment in turning, grinding and other production machines.

Owing to the application of bearing and the stable construction high axial and radial load can be absorbed accurately. Therefore our live centers are outstanding for any application, especially for tooling with face drivers.

Type RN with morse taper

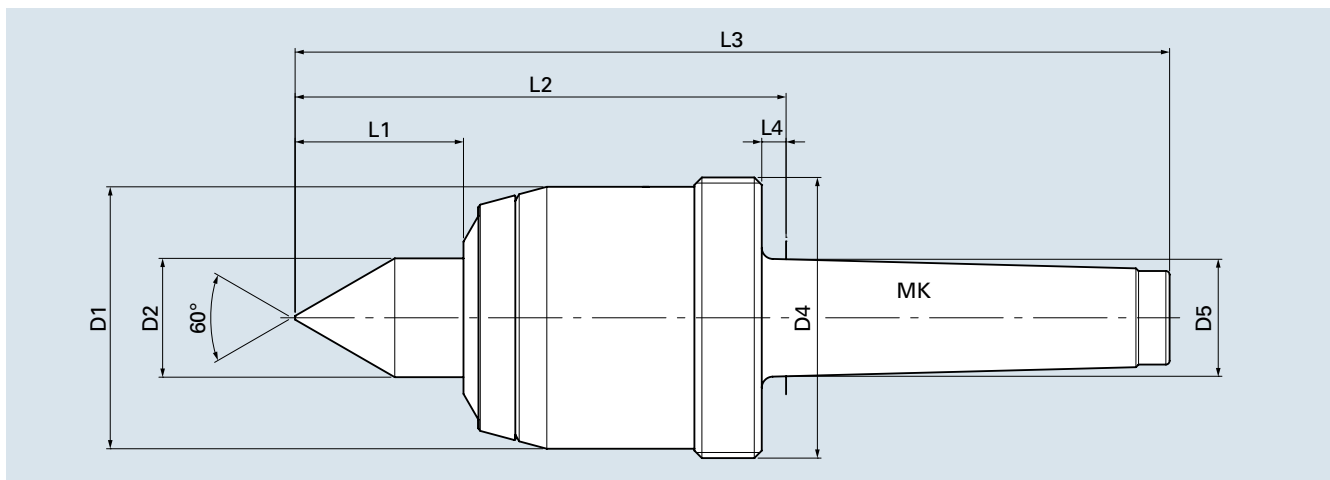

cat. no. turning	cat. no. grinding	type	MK	D1	D2	D4	D5	L1	L2	L3	L4	rpm max. [1/min]	weight of work piece max. [kg]	axial load max. [daN]
81201	8120102	RN3 MK3	3	55	22	M58 x 1.5	23.83	26	102	183	5	8000	440	500
81202	8120202	RN3 MK4	4	55	22	M58 x 1.5	31.27	26	103.5	206	6.5	8000	440	500
81203	8120302	RN3 MK5	5	55	22	M58 x 1.5	44.40	26	103.5	233	6.5	8000	440	500
81204	8120402	RN4 MK4	4	70	32	M75 x 1.5	31.27	45	131.2	233.7	6.5	7000	700	800
81205	8120502	RN4 MK5	5	70	32	M75 x 1.5	44.40	45	131.2	260.7	6.5	7000	700	800
81206	8120602	RN5 MK5	5	92	45	M95 x 2	44.40	60	156.2	285.7	6.5	5000	1400	1500
81207	8120702	RN5 MK6	6	92	45	M95 x 2	63.35	60	157.7	339.7	8	5000	1400	1500
81208	8120802	RN6 MK6	6	107	55	M110 x 2	63.35	60	169.7	351.7	8	3000	2000	2000

## NEIDLEIN revolving ultra live centers type RN ensure:

- Application of live centers in case of high thrust and loading.
- high true running accuracy  
max. 0.005 turning type  
max. 0.003 grinding type
- enhanced true running accuracy HQ  
All our specified live centers can be obtained with enhanced true running accuracy of max. 0.002.  
cat. no. = 812XX1  
e.g. RN4 MK4 type HQ cat. no. 812041
- Maintenance-free, due to gasket system and lifetime lubrication of bearings. Gasket system comprising variable seal and steel protection cover.
- Excellent demounting by means of extracting nut and extracting disk, which ensures safe and easy removal of the live center from the tailstock spindle sleeve.

Extracting nuts and extracting disks see page 19 for accessories.



### Type turning

- with contact-free labyrinth seal

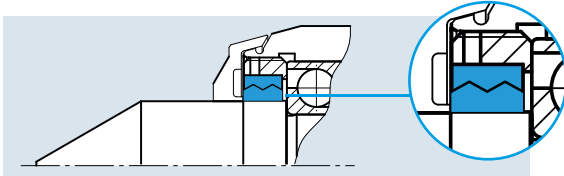

- true running accuracy max. 0.005 guaranteed

### Type grinding

- with contact shaft seal

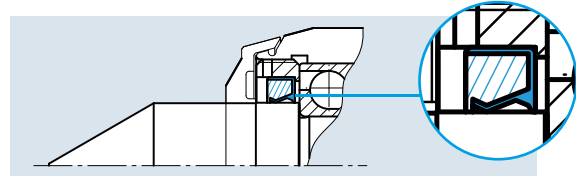

- true running accuracy max. 0.003 guaranteed

### Type RN with carbide tip for hardened work pieces

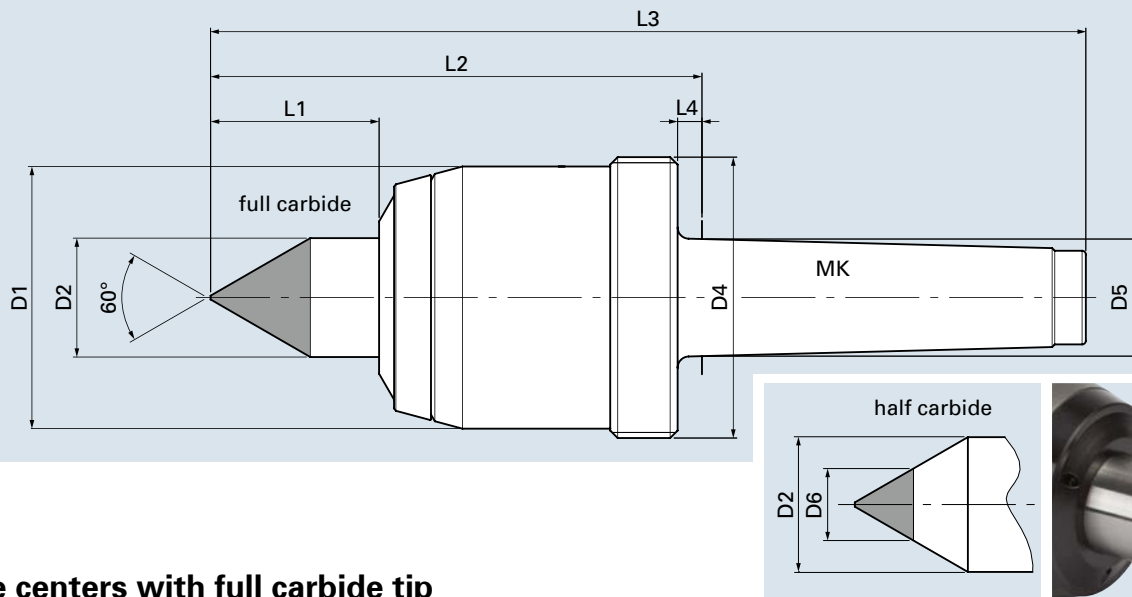

### Live centers with full carbide tip

cat. no. turning	cat. no. grinding	type full carbide	MK	D1	D2	D4	D5	L1	L2	L3	L4	rpm max. [1/min]	weight of work piece max. [kg]	axial load max. [daN]
8120104	8120106	RN3 MK3	3	55	22	M58 x 1.5	23.83	26	102	183	5	8000	440	500
8120204	8120206	RN3 MK4	4	55	22	M58 x 1.5	31.27	26	103.5	206	6.5	8000	440	500
8120304	8120306	RN3 MK5	5	55	22	M58 x 1.5	44.40	26	103.5	233	6.5	8000	440	500
8120404	8120406	RN4 MK4	4	70	32	M75 x 1.5	31.27	45	131.2	233.7	6.5	7000	700	800
8120504	8120506	RN4 MK5	5	70	32	M75 x 1.5	44.40	45	131.2	260.7	6.5	7000	700	800
8120604	8120606	RN5 MK5	5	92	45	M95 x 2	44.40	60	156.2	285.7	6.5	5000	1400	1500
8120704	8120706	RN5 MK6	6	92	45	M95 x 2	63.35	60	157.7	339.7	8	5000	1400	1500
8120804	8120806	RN6 MK6	6	107	55	M110 x 2	63.35	60	169.7	351.7	8	3000	2000	2000

### Live centers with half-carbide tip

cat. no. turning	cat. no. grinding	type half carbide	MK	D1	D2	D4	D5	D6	L1	L2	L3	L4	rpm max. [1/min]	weight of work piece max. [kg]	axial load max. [daN]
8120103	8120105	RN3 MK3	3	55	22	M58 x 1.5	23.83	11	26	102	183	5	8000	440	500
8120203	8120205	RN3 MK4	4	55	22	M58 x 1.5	31.27	11	26	103.5	206	6.5	8000	440	500
8120303	8120305	RN3 MK5	5	55	22	M58 x 1.5	44.40	11	26	103.5	233	6.5	8000	440	500
8120403	8120405	RN4 MK4	4	70	32	M75 x 1.5	31.27	14	45	131.2	233.7	6.5	7000	700	800
8120503	8120505	RN4 MK5	5	70	32	M75 x 1.5	44.40	14	45	131.2	260.7	6.5	7000	700	800
8120603	8120605	RN5 MK5	5	92	45	M95 x 2	44.40	22	60	156.2	285.7	6.5	5000	1400	1500
8120703	8120705	RN5 MK6	6	92	45	M95 x 2	63.35	22	60	157.7	339.7	8	5000	1400	1500
8120803	8120805	RN6 MK6	6	107	55	M110 x 2	63.35	28	60	169.7	351.7	8	3000	2000	2000

Extracting nuts and extracting disks see page 19 for accessories.

# Ultra Live Center RNC

## Clamping tools for clamping on machine tools

NEIDLEIN ultra live centers are designed for employment in turning, grinding and other production machines.

### → extended tooling space

For better access of cutting tools in case of limited tooling space.

Type RNC with morse taper

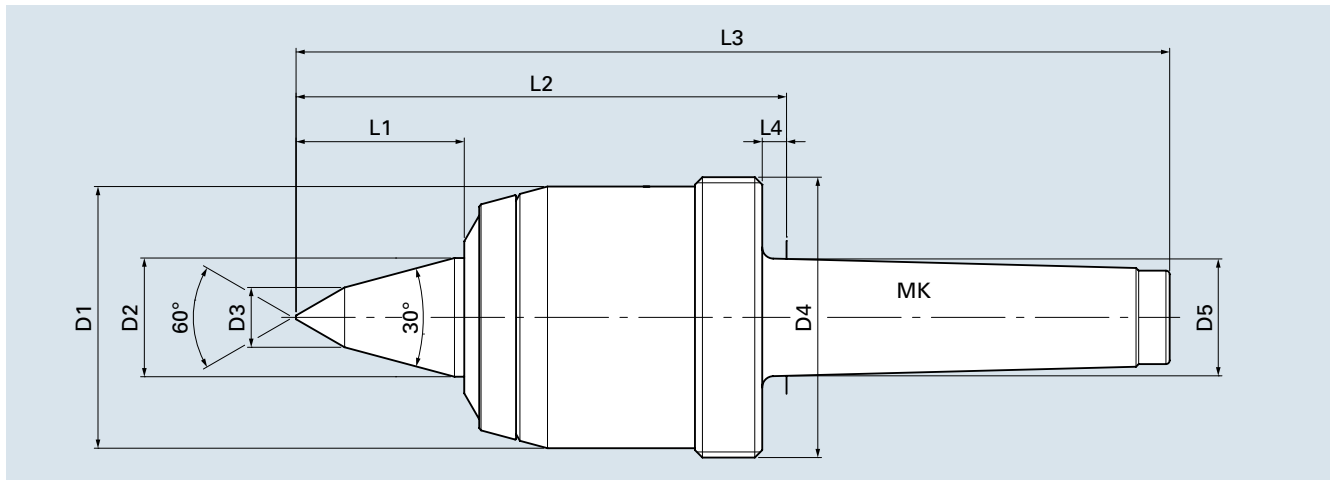

cat. no. turning	cat. no. grinding	type	MK	D1	D2	D3	D4	D5	L1	L2	L3	L4	rpm max. [1/min]	weight of work piece max. [kg]	axial load max. [daN]
81301	8130102	RNC3 MK3	3	55	22	10	M58 x 1.5	23.83	32	108	189	5	8000	440	500
81302	8130202	RNC3 MK4	4	55	22	10	M58 x 1.5	31.27	32	109.5	212	6.5	8000	440	500
81303	8130302	RNC3 MK5	5	55	22	10	M58 x 1.5	44.40	32	109.5	239	6.5	8000	440	500
81304	8130402	RNC4 MK4	4	70	32	16	M75 x 1.5	31.27	45	131.2	233.7	6.5	7000	700	800
81305	8130502	RNC4 MK5	5	70	32	16	M75 x 1.5	44.40	45	131.2	260.7	6.5	7000	700	800
81306	8130602	RNC5 MK5	5	92	45	22	M95 x 2	44.40	62	158.2	287.7	6.5	5000	1400	1500
81307	8130702	RNC5 MK6	6	92	45	22	M95 x 2	63.35	62	159.7	341.7	8	5000	1400	1500
81308	8130802	RNC6 MK6	6	107	55	28	M110 x 2	63.35	72	181.7	363.7	8	3000	2000	2000

## NEIDLEIN revolving ultra live centers type RNC ensure:

- Application of live centers in case of high thrust and loading.
- high true running accuracy  
max. 0.005 turning type  
max. 0.003 grinding type
- enhanced true running accuracy HQ  
All our specified live centers can be obtained with enhanced true running accuracy of max. 0.002.  
cat. no. = 813XX1  
e.g. RN4 MK4 type HQ cat. no. 813041
- Maintenance-free, due to gasket system and lifetime lubrication of bearings. Gasket system comprising variable seal and steel protection cover.
- Excellent demounting by means of extracting nut and extracting disk, which ensures safe and easy removal of the live center from the tailstock spindle sleeve.

Extracting nuts and extracting disks see page 19 for accessories.



### Type turning

- with contact-free labyrinth seal

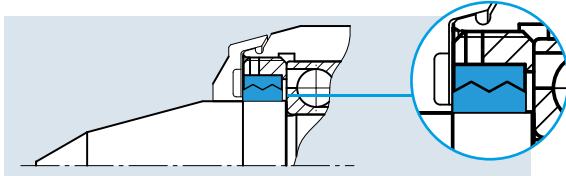

- true running accuracy max. 0.005 guaranteed

### Type grinding

- with contact shaft seal

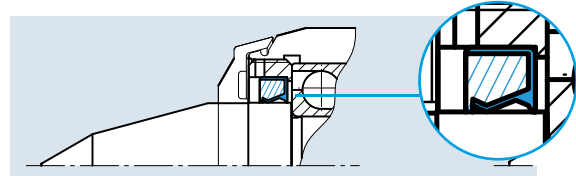

- true running accuracy max. 0.003 guaranteed

### Type RNC with carbide tip for hardened work pieces

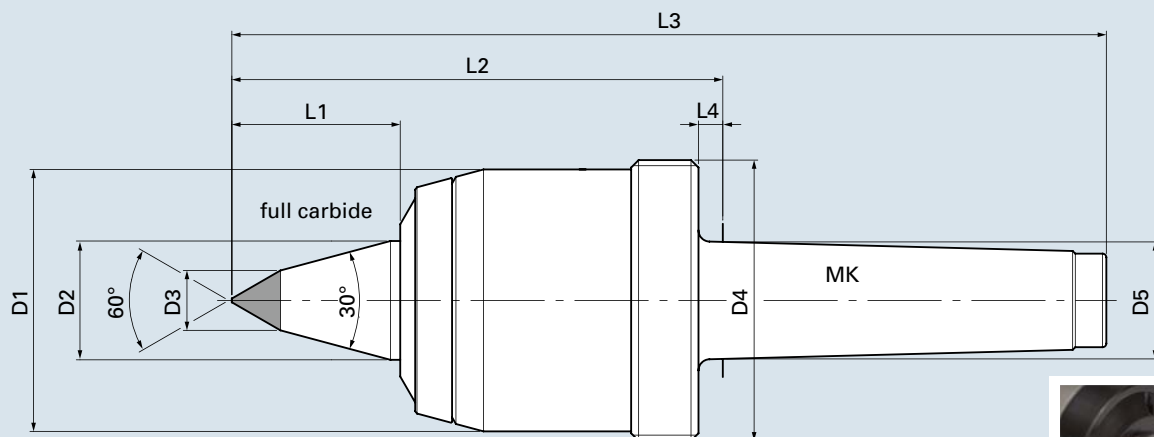

### Live centers with carbide tip

cat. no. turning	cat. no. grinding	type carbide	MK	D1	D2	D3	D4	D5	L1	L2	L3	L4	rpm max. [1/min]	weight of work piece max. [kg]	axial load max. [daN]
8130104	8130106	RNC3 MK3	3	55	22	10	M58 x 1.5	23.83	32	108	189	5	8000	440	500
8130204	8130206	RNC3 MK4	4	55	22	10	M58 x 1.5	31.27	32	109.5	212	6.5	8000	440	500
8130304	8130306	RNC3 MK5	5	55	22	10	M58 x 1.5	44.40	32	109.5	239	6.5	8000	440	500
8130404	8130406	RNC4 MK4	4	70	32	16	M75 x 1.5	31.27	45	131.2	233.7	6.5	7000	700	800
8130504	8130506	RNC4 MK5	5	70	32	16	M75 x 1.5	44.40	45	131.2	260.7	6.5	7000	700	800
8130604	8130606	RNC5 MK5	5	92	45	22	M95 x 2	44.40	62	158.2	287.7	6.5	5000	1400	1500
8130704	8130706	RNC5 MK6	6	92	45	22	M95 x 2	63.35	62	159.7	341.7	8	5000	1400	1500
8130804	8130806	RNC6 MK6	6	107	55	28	M110 x 2	63.35	72	181.7	363.7	8	3000	2000	2000

Extracting nuts and extracting disks see page 19 for accessories.



# Ultra Live Center RNA

## Clamping tools for clamping on machine tools

NEIDLEIN ultra live centers type RNA are designed for employment in turning and other production machines.

➔ **for large work piece centers**  
High degree of flexibility for clamping of work pieces with large centers.

**Variety of center cones ranging from Ø 25 to Ø315, see page 16.**  
Special cones up to Ø400 available upon customer's request.

Type RNA with morse taper

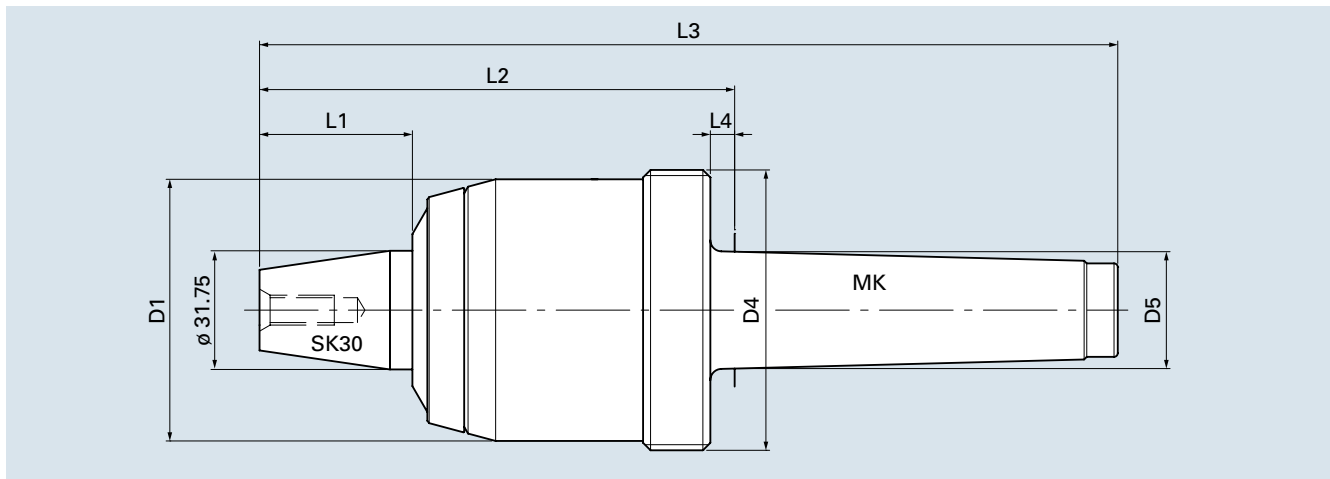

cat. no.	type	MK	D1	D4	D5	L1	L2	L3	L4	rpm max. [1/min]	weight of work piece max. [kg]	axial load max. [daN]
81404	RNA4 MK4	4	70	M75 x 1.5	31.27	41	127	229.5	6.5	7000	700	800
81405	RNA4 MK5	5	70	M75 x 1.5	44.40	41	127	256.5	6.5	7000	700	800
81406	RNA5 MK5	5	92	M95 x 2	44.40	41	137.2	266.7	6.5	5000	1400	1500
81407	RNA5 MK6	6	92	M95 x 2	63.35	41	138.7	320.7	8	5000	1400	1500
81408	RNA6 MK6	6	107	M110 x 2	63.35	41	150.7	332.7	8	3000	2000	2000

## NEIDLEIN revolving ultra live centers type RNA ensure:

- Application of live centers in case of high thrust and loading.
- true running accuracy max. 0.01
- Easy exchange of center cones using SK30 short taper interface and cylinder screw.
- Maintenance-free, due to gasket system and lifetime lubrication of bearings. Gasket system comprising variable seal and steel comprehensive protection cover.
- Excellent demounting by means of extracting nut and extracting disk, which ensures safe and easy removal of the live center from the tailstock spindle sleeve.

Abdrückmuttern und Abdrückscheiben unter Zubehör auf Seite 19



## Ultra Live Center RNW

### Clamping tools for clamping on machine tools

NEIDLEIN ultra live centers type RNW are designed for employment in turning and other production machines.

#### ➔ maximum flexibility

The adaptation of various changeable inserts ensures a high degree of flexibility and saving of costs.

#### Various changeable inserts of different designs, see page 17.

Special inserts available upon customer's request.

Type RNW with morse taper

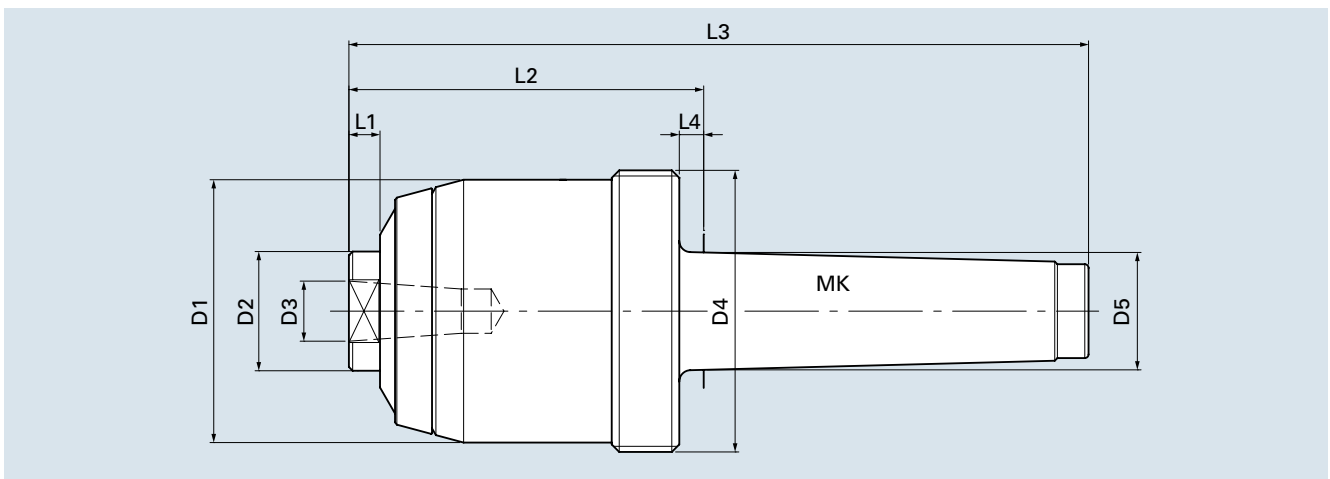

cat. no.	type	MK	D1	D2	D3	D4	D5	L1	L2	L3	L4	rpm max. [1/min]	weight of work piece max. [kg]	axial load max. [daN]
81501	RNW3 MK3	3	55	22	16	M58 x 1.5	23.83	6.3	82	163	5	8000	440	500
81502	RNW3 MK4	4	55	22	16	M58 x 1.5	31.27	6.3	83.5	186	6.5	8000	440	500
81503	RNW3 MK5	5	55	22	16	M58 x 1.5	44.40	6.3	83.5	213	6.5	8000	440	500
81504	RNW4 MK4	4	70	32	16	M75 x 1.5	31.27	8.3	94.5	197	6.5	7000	700	800
81505	RNW4 MK5	5	70	32	16	M75 x 1.5	44.40	8.3	94.5	224	6.5	7000	700	800
81506	RNW5 MK5	5	92	45	22	M95 x 2	44.40	10.3	106.5	236	6.5	5000	1400	1500
81507	RNW5 MK6	6	92	45	22	M95 x 2	63.35	10.3	108	290	8	5000	1400	1500
81508	RNW6 MK6	6	107	55	22	M110 x 2	63.35	10.3	120	302	8	3000	2000	2000

### NEIDLEIN revolving ultra live centers type RNW ensure:

- Application of live centers in case of high thrust and loading.
- true running accuracy max. 0.01
- Easy exchange of changeable inserts using spanner flat and open-end wrench or Tommy bar.
- Maintenance-free, due to gasket system and life-time lubrication of bearings. Gasket system comprising variable seal and steel comprehensive protection cover.
- Excellent demounting by means of extracting nut and extracting disk, which ensures safe and easy removal of the live center from the tailstock spindle sleeve.

Extracting nuts and extracting disks see page 19 for accessories.

# Ultra Live Centers Type Cone Head RKA

## Clamping tools for clamping on machine tools

NEIDLEIN ultra live centers type cone head RKA are designed for heavy work pieces with large centers.

The **modular clamping system** allows for a high degree of flexibility. It enables clamping of work pieces with centers from **Ø50 to Ø460**.

Type RKA basic retainer with morse taper

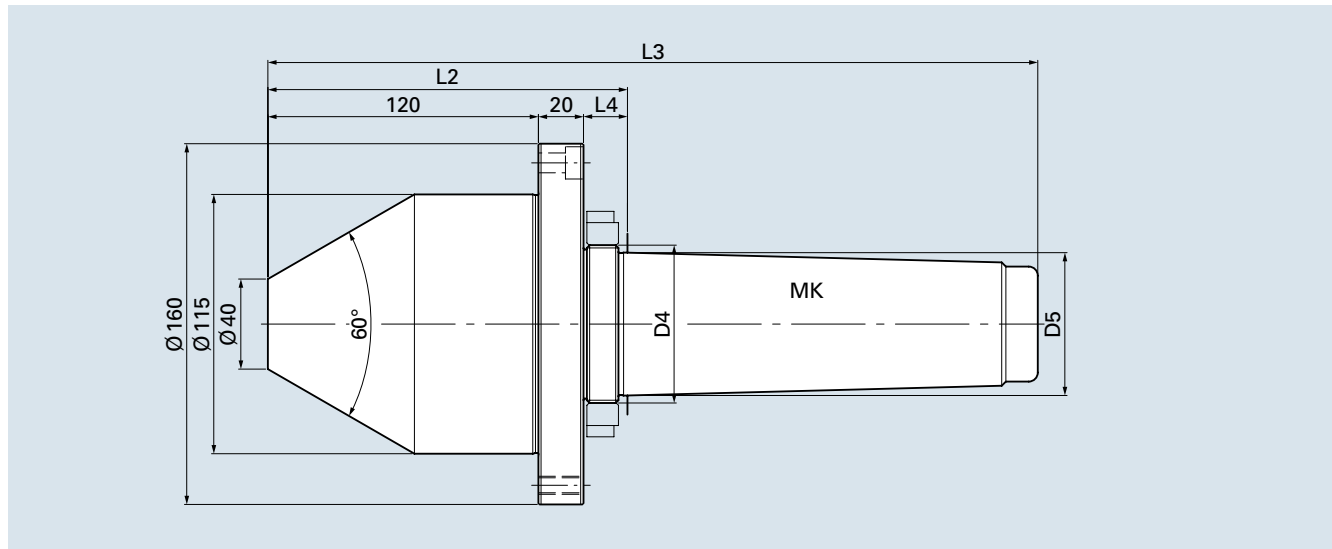

Work pieces with centers between Ø40 and Ø115 can be clamped using the basic retainer. Basic retainer including extraction nut.

cat. no.	type	MK	D4	D5	L2	L3	L4	rpm max. [1/min]	weight of work piece max. [kg]	axial load max. [daN]
81409	RKA6 MK5	5	M48 x 1.5	44.40	158.5	288	18.5	3000	2500	2000
81410	RKA6 MK6	6	M70 x 1.5	63.35	159.5	341.5	19.5	3000	3000	2000

- True running accuracy max. 0.005 without fail.
- Special basic retainer available upon customer's request.

Accessories on page 18





## Ultra Live Center RNF

### Clamping tools for clamping on machine tools

NEIDLEIN ultra live centers type RNF are especially suitable for employment in turrets, in manual tailstocks and in case of linear thermal extension of work pieces.

The spring loaded, moving spindle and the engraved scale rings enable the adjustment and/or programming of various axial forces.

Type RNF with morse taper

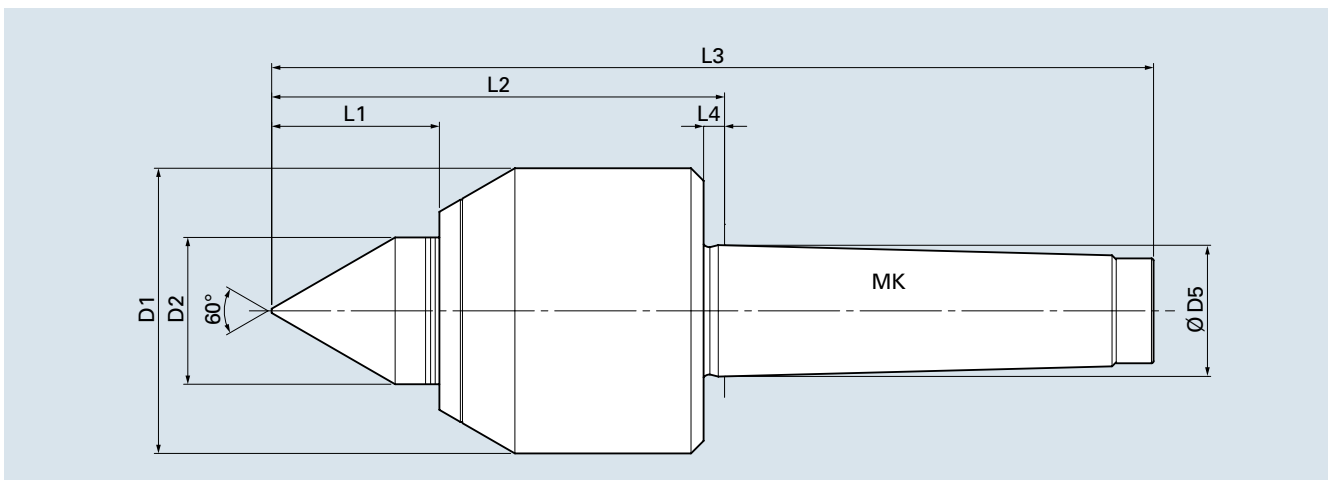
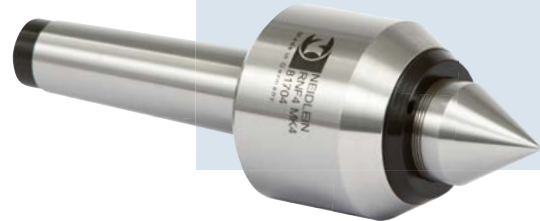

cat. no.	type	MK	D1	D2	D5	L1	L2	L3	L4	rpm max. [1/min]	weight of work piece max. [kg]	axial load max. [daN]
81701	RNF3 MK3	3	55	25	23.83	28.5	84.5	165	5	4500	350	730
81702	RNF3 MK4	4	55	25	31.27	28.5	86	185.5	6.5	4500	350	730
81703	RNF3 MK5	5	55	25	44.40	28.5	86	215.5	6.5	4500	350	730
81704	RNF4 MK4	4	68	35	31.27	40	109.5	210.3	6.5	4000	900	800
81705	RNF4 MK5	5	68	35	44.40	40	109.5	239	6.5	4000	900	800

● Models with extraction thread or with special spindles are available upon customer's request.

### NEIDLEIN ultra live centers type RNF ensure:

- Employment of live centers in turrets and manual tailstocks when hydraulic systems cannot guarantee any repositioning.
- Compensation if there is a linear thermal extension of work pieces or if the extension is caused by the process of machining.
- High true run-out accuracy **max. 0,003**
- Maintenance free, due to the gasket system and the lifetime lubrication filling of the bearing.
- Obtaining of the axial forces applied via scale rings as well as clarification of the force ranges on the outside of the housing.



# Ultra Live Ceter RNCF

## Clamping tools for clamping on machine tools

NEIDLEIN ultra live centers type RNCF are especially suitable for employment in turrets, in manual tailstocks and in case of linear thermal extension of work pieces.

### → extended working space

For better access of machining tools if there is limited working space.

Type RNCF with morse taper

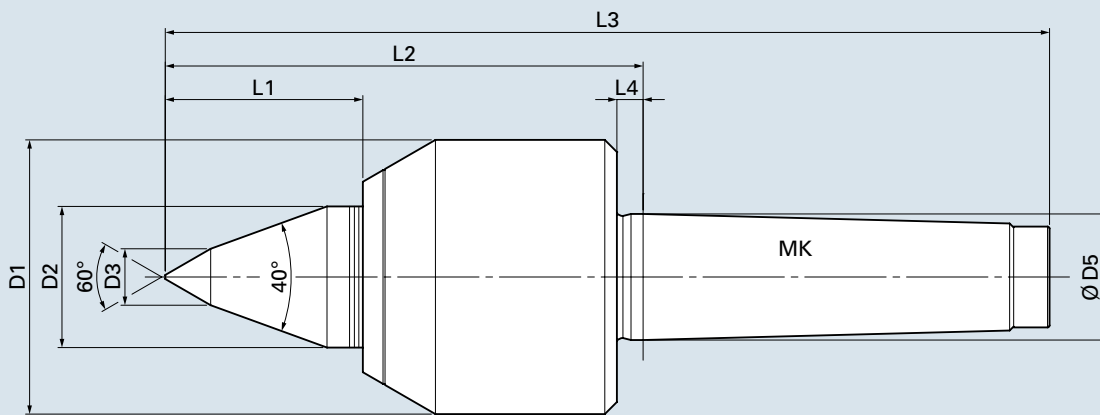

cat. no.	type	MK	D1	D2	D3	D5	L1	L2	L3	L4	rpm max. [1/min]	weight of work piece max. [kg]	axial load max. [daN]
81801	RNCF3 MK3	3	55	25	12	23.83	37	93	173.5	5	4500	350	730
81802	RNCF3 MK4	4	55	25	12	31.27	37	94.5	194	6.5	4500	350	730
81803	RNCF3 MK5	5	55	25	12	44.40	37	94.5	224	6.5	4500	350	730
81804	RNCF4 MK4	4	68	35	14	31.27	49	118.5	219.3	6.5	4000	900	800
81805	RNCF4 MK5	5	68	35	14	44.40	49	118.5	248	6.5	4000	900	800

● Models with extraction thread or with special spindles are available upon customer's request.

## NEIDLEIN travelling ultra live centers type RNCF ensure:

- Employment of live centers in turrets and manual tailstocks when hydraulic systems cannot guarantee any repositioning.
- Compensation if there is a linear thermal extension of work pieces or if the extension is caused by the process of machining.
- High true run-out accuracy **max. 0,003**
- Maintenance free, due to the gasket system and the lifetime lubrication filling of the bearing.
- Obtaining of the axial forces applied via scale rings as well as clarification of the force ranges on the outside of the housing.





## Ultra Live Center RNF / RNCF VDI

### Clamping tools for clamping on machine tools

NEIDLEIN ultra live centers type RNF/RNCF VDI are adapted in the tool turret and are especially suited for CNC machines without tailstock or with sub spindle.

The spring loaded, moving spindle and the engraved scale rings enable the adjustment and/or programming of various axial forces.



#### Type RNF with VDI retainer

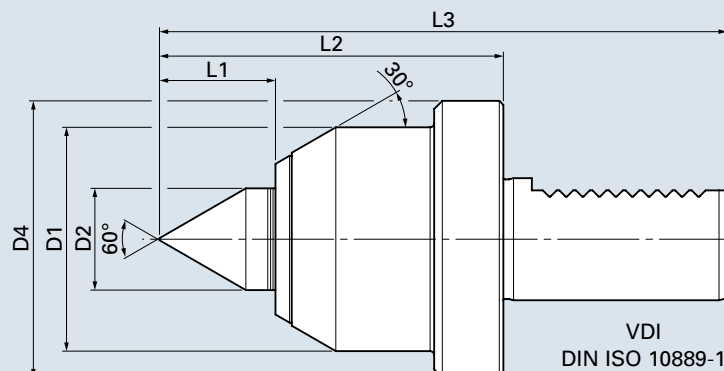

cat. no.	type	VDI	D1	D2	D4	L1	L2	L3	rpm max. [1/min]	weight of work piece max. [kg]	axial load max. [daN]
81706	RNF3 VDI30	30	55	25	68	28.5	84.5	139.5	4500	350	730
81707	RNF3 VDI40	40	55	25	83	28.5	84.5	147.5	4500	350	730
81708	RNF4 VDI40	40	68	35	83	40	108	171	4000	900	800

● True run-out accuracy max. 0.003

#### Type RNCF with VDI retainer

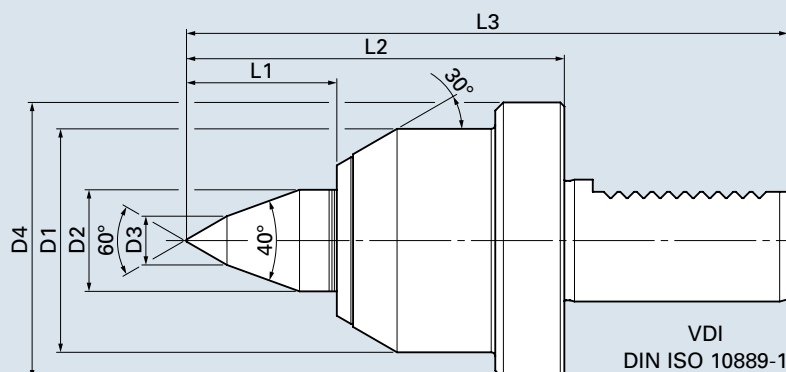

cat. no.	type	VDI	D1	D2	D3	D4	L1	L2	L3	rpm max. [1/min]	weight of work piece max. [kg]	axial load max. [daN]
81806	RNCF3 VDI30	30	55	25	12	68	37	93	148	4500	350	730
81807	RNCF3 VDI40	40	55	25	12	83	37	93	156	4500	350	730
81808	RNCF4 VDI40	40	68	35	14	83	49	117	180	4000	900	800

● True run-out accuracy max. 0.003

# Dead Centers FN / FNC

## Clamping tools for clamping on machine tools

Rotating and fixed tailstock spindle sleeve. Designed for employment in turning, grinding and other production machines.

made of full-hardened tool steel

➔ can be reground

### Type FN with morse taper

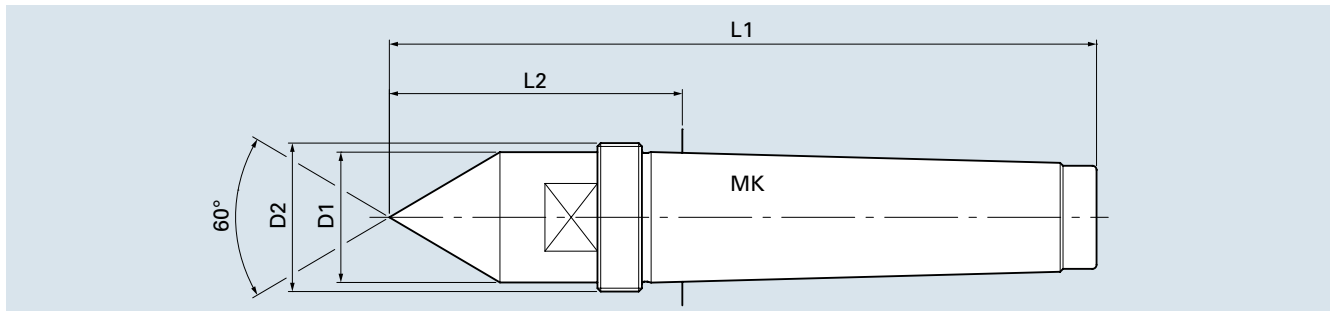

cat. no.	type	MK	D1	D2	L1	L2
92001	FN MK3	3	24	M27 x 1.5	138	57
92002	FN MK4	4	32	M36 x 1.5	175	72
92003	FN MK5	5	45	M48 x 1.5	217	87
92004	FN MK6	6	64	M68 x 1.5	290	108

● high true running accuracy max. 0.002

### Type FNC with morse taper



➔ extended working space

For better access of cutting tools in case of limited working space.

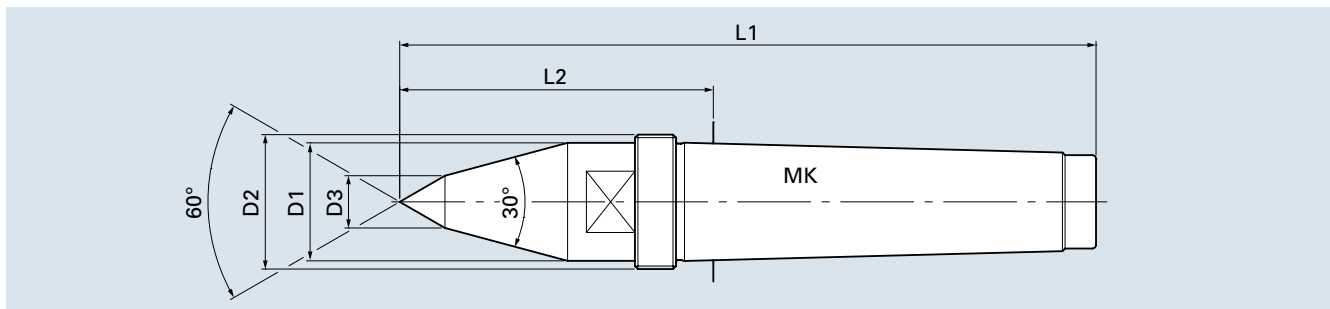

cat. no.	type	MK	D1	D2	D3	L1	L2
92101	FNC MK3	3	24	M27 x 1.5	10	148	67
92102	FNC MK4	4	32	M36 x 1.5	14	187	84
92103	FNC MK5	5	45	M48 x 1.5	16	242	112
92104	FNC MK6	6	64	M68 x 1.5	20	330	148

● high true running accuracy max. 0.002

All types with extracting thread to prevent spindle ball bearings or solid spindle sleeves from damage. Extracting nuts see page 19 for accessories.



## Dead Centers FNA / FNW

### Clamping tools for clamping on machine tools

→ for large work piece centers

High degree of flexibility for clamping of work pieces with large centers.

Different types of center cones from Ø25 to Ø315, see page 16.

Special center cones up to Ø400 available upon customer's request.

#### Type FNA with morse taper

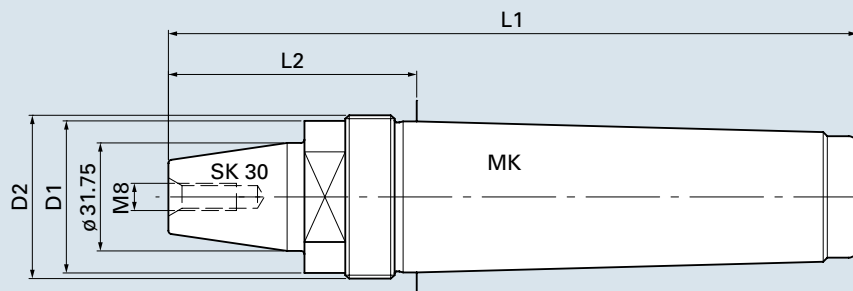

cat. no.	type	MK	D1	D2	L1	L2
92201	FNA MK3	3	32	M27 x 1.5	149	68
92202	FNA MK4	4	32	M36 x 1.5	173.5	71
92203	FNA MK5	5	45	M48 x 1.5	202.5	73
92204	FNA MK6	6	64	M68 x 1.5	263.5	81.5

● true running accuracy at center cone: max. 0.01

→ maximum flexibility

The adaptation of various changeable inserts ensures a high degree of flexibility and saving of costs.

Various changeable inserts of different designs, see page 17.

Special inserts available upon customer's request.

#### Type FNW with morse taper

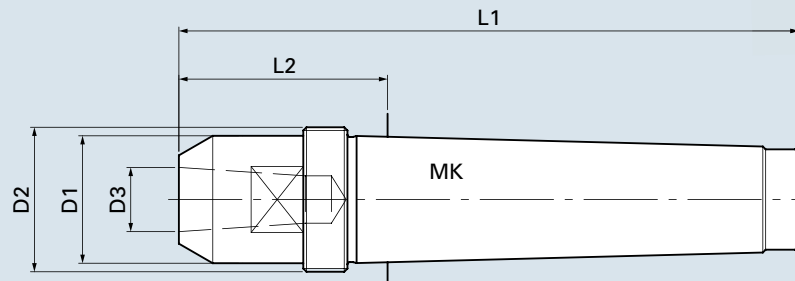

cat. no.	type	MK	D1	D2	D3	L1	L2
92301	FNW MK3	3	24	M27 x 1.5	16	121	40
92302	FNW MK4	4	32	M36 x 1.5	16	154.5	52
92303	FNW MK5	5	45	M48 x 1.5	22	190	60
92304	FNW MK6	6	64	M68 x 1.5	22	252	70

● true running accuracy at center cone: max. 0.01

Extracting nuts, see page 19 for accessories.



# Carbide Center Pins DIN 806

## Clamping tools for clamping on machine tools

**To be applied with hardened work pieces**  
For headstocks and fixed tailstock spindle sleeves.  
Designed for employment in grinding and other  
production machines.

### Type DIN 806 option model E/HE



### Type DIN 806 model E

with half carbide tip

cat. no.	MK	D1	D3	L1	L2
91001	1	12.2	7	80	26.5
91003	2	18	7	100	36
91006	3	24.1	11	125	44
91009	4	31.6	14	160	57.5
91012	5	44.7	18	200	70.5
91015	6	63.8	18	270	88

● hohe Rundlaufgenauigkeit: max. 0,002

### Type similar to DIN 806 model E

with full carbide tip

cat. no.	MK	D1	L1	L2
91002	1	12.2	80	26.5
91005	2	18	100	36
91008	3	24.1	125	44
91011	4	31.6	160	57.5
91014	5	44.7	200	70.5
91018	6	63.8	270	88

● high true running accuracy max. 0.002

### Type DIN 806 model HE

flattened with half carbide tip

cat. no.	MK	D1	D3	L1	L2	h
91101	1	12.2	7	80	26.5	1.5
91102	2	18	7	100	36	2
91104	3	24.1	11	125	44	3
91106	4	31.6	14	160	57.5	5
91108	5	44.7	18	200	70.5	7
91110	6	63.8	18	270	88	10

● high true running accuracy max. 0.002

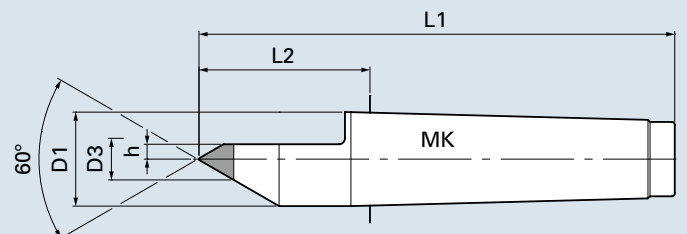
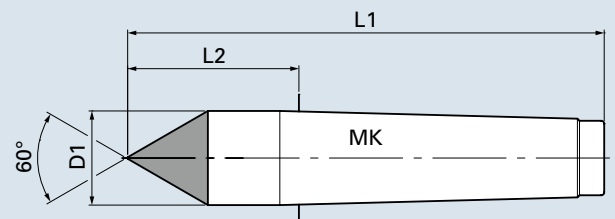
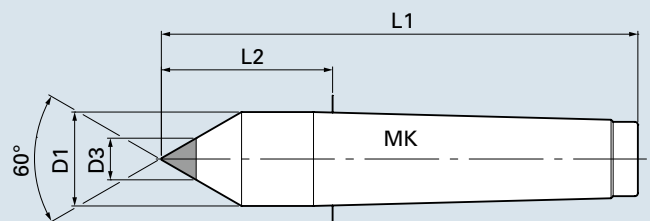



## Carbide Center Pins DIN 807

### Clamping tools for clamping on machine tools

#### → with extraction screw thread

DIN 807 with extraction screw thread to prevent spindle ball bearings or unpierced spindle sleeves from damage. Extracting nuts, see page 19 for accessories. Available with spanner flat upon request.

#### Type DIN 807 model E/HE

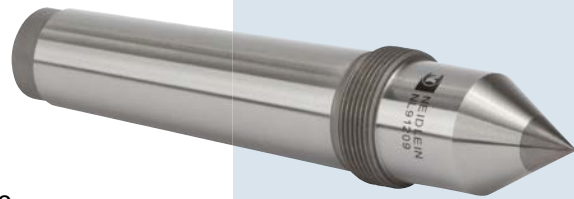

#### Type DIN 807 model E

with half carbide pin

cat. no.	MK	D1	D2	D3	L1	L2
91201	1	12.2	16 x 1.5	7	90	36.5
91203	2	18	22 x 1.5	7	112	48
91206	3	24.1	27 x 1.5	11	138	57
91209	4	31.6	36 x 1.5	14	175	72.5
91212	5	44.7	48 x 1.5	18	217	87.5
91215	6	63.8	68 x 1.5	18	290	108

● high true running accuracy max. 0.002

#### Type similar to DIN 807 model E

with full carbide pin

cat. no.	MK	D1	D2	L1	L2
91202	1	12.2	16 x 1.5	90	36.5
91205	2	18	22 x 1.5	112	48
91208	3	24.1	27 x 1.5	138	57
91211	4	31.6	36 x 1.5	175	72.5
91214	5	44.7	48 x 1.5	217	87.5
91218	6	63.8	68 x 1.5	290	108

● high true running accuracy max. 0.002

#### Type DIN 807 model HE

flattened with half carbide tip

cat. no.	MK	D1	D2	D3	L1	L2	h
91301	1	12.2	16 x 1.5	7	90	36.5	1.5
91303	2	18	22 x 1.5	7	112	48	2
91306	3	24.1	27 x 1.5	11	138	57	3
91309	4	31.6	36 x 1.5	14	175	72.5	5
91312	5	44.7	48 x 1.5	18	217	87.5	7
91315	6	63.8	68 x 1.5	18	290	108	10

● high true running accuracy max. 0.002

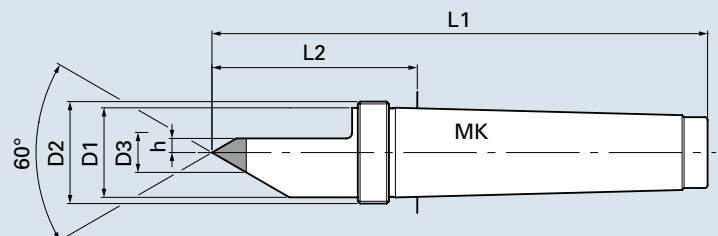
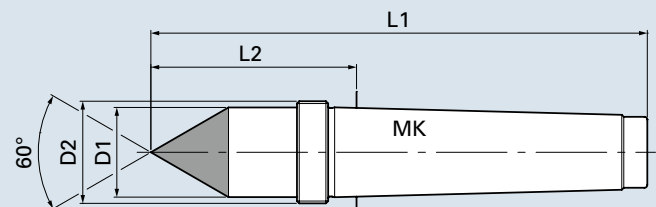
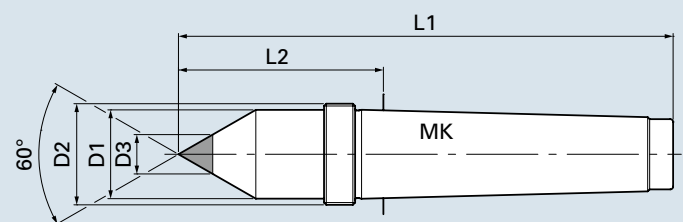

Extracting nuts, see accessories page 19.

# Changeable Center Cone for RNA / FNA

## Clamping tools for clamping on machine tools

### Center cones for large work piece centers

High degree of flexibility for clamping of work pieces with large centers.

Suitable for live centers type RNA on page 6 and for dead centers type FNA on page 13.

Special cones up to  $\varnothing 400$  available upon customer's request.

For type RNA / FNA with SK30 interface



## For types RNA and FNA

cat. no.	W1	D1	D2	L
<b>81450</b>	60	20	85	60
<b>81451</b>	60	70	135	60
<b>81452</b>	60	120	185	60
<b>81453</b>	60	170	235	60
<b>81454</b>	60	220	285	60
<b>81455</b>	75	20	105	60
<b>81456</b>	75	90	175	60
<b>81457</b>	75	160	245	60
<b>81458</b>	75	230	315	60
<b>81459</b>	90	20	130	60
<b>81460</b>	90	100	210	60
<b>81461</b>	90	180	290	60

The center cones are fastened with a screw M8 DIN 912 onto the base body.

The center cones can be forced off with a screw M10.

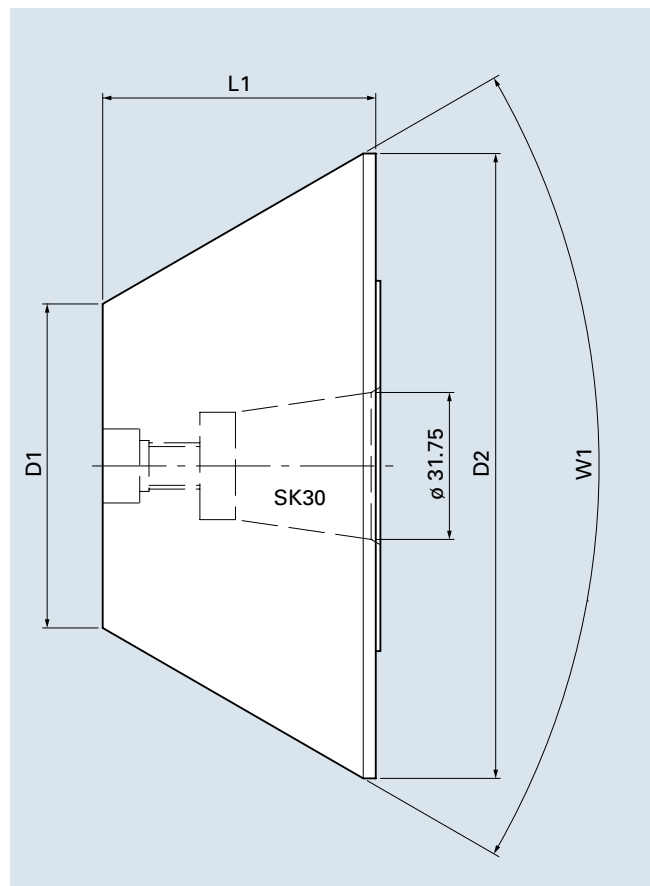



## Changeable Inserts for RNW / FNW

### Clamping tools for clamping on machine tools

#### Changeable inserts for a maximum of flexibility

The adaptation of various changeable inserts ensures a high degree of flexibility and saving of costs.

Suitable for live centers type RNW on page 7 and for the dead centers type FNW on page 13.

Special inserts available upon customer's request.

### For types RNW 3 and 4 FNW MK3 and 4

cat. no.	type	D1	D2	D3	D4	L
81550	A	22	-	-	16	30
81551	B	22	10	-	16	40
81552	C	22	7	10	16	30
81553	D	22	11	-	16	30
81554	E	55	21	-	16	35
81555	F	55	50	10	16	30
81556	G	22	10	-	16	40

### For types RNW 5 and 6 FNW MK5 and 6

cat. no.	type	D1	D2	D3	D4	L
81560	A	34	-	-	22	35
81561	B	34	16	-	22	45
81562	C	34	10	7	22	29
81563	D	34	18	-	22	35
81564	E	70	33	-	22	38
81565	F	70	64	24	22	34
81566	G	34	16	-	22	45

For type RNW / FNW with taper interface

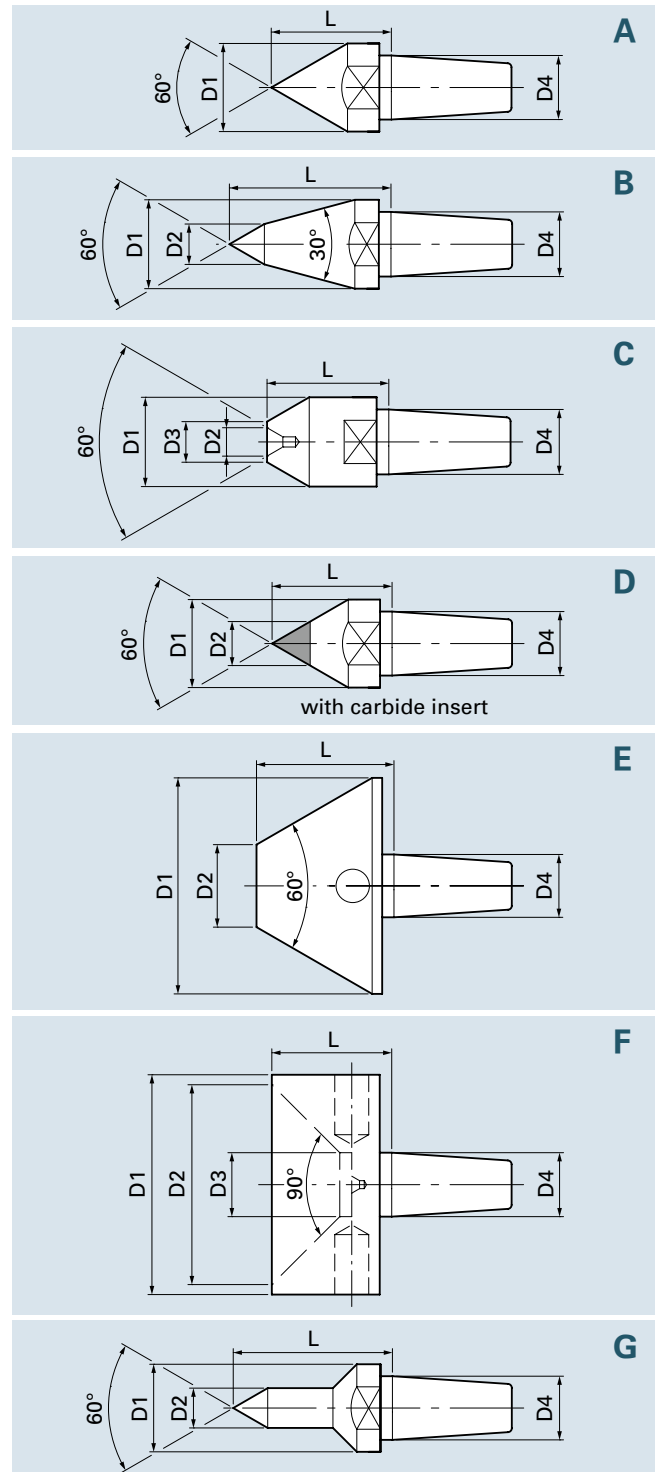

For quick demounting all changeable inserts come with spanner flat or cross hole.

# Changeable Center Cone for RKA

## Clamping tools for clamping on machine tools

Work pieces with large center holes from  $\varnothing 120$  to  $\varnothing 460$  are clamped with a basic retainer and a changeable center cone.

### For type RKA

cat. no.	D1	D2
<b>81480</b>	113	220
<b>81481</b>	195	275
<b>81482</b>	270	350
<b>81483</b>	345	425
<b>81484</b>	380	460

True run-out accuracy max 0.02 at changeable center cone is guaranteed.

Special changeable center cones ( $90^\circ/75^\circ$ / various diameters) available upon customer's request.

Suitable for live center type RKA on page 8.

### Type RKA centering taper

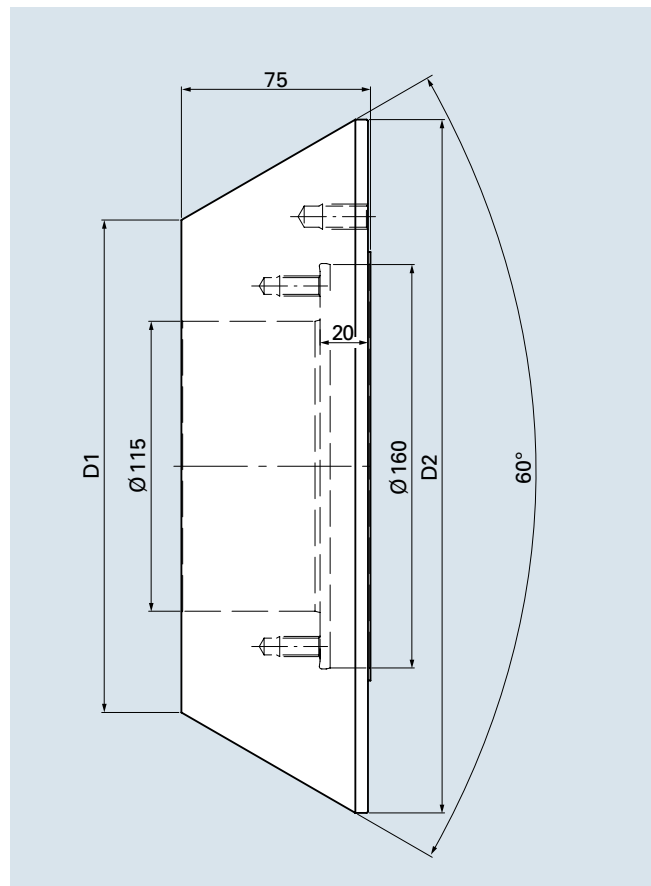





## Extracting Nuts and Extracting Disks

### Clamping tools for clamping on machine tools

#### Accessories for demounting

Accessories for safe and quick demounting of our ultra live centers, dead centers, center pins and face drivers.

#### Extracting nut type DIN 1804 h

for ultra live centers

type RN/RNC/RNA/RNW

cat. no.	size	D1	D2	D3	h
83022	3	M58 x 1.5	80	90	13
83023	4	M75 x 1.5	100	110	14
83024	5	M95 x 2	120	135	16
83025	6	M110 x 2	140	155	16

for other center pins and face drivers

cat. no.	D1	D2	D3	h
83039	M28 x 1.5	43	50	10
83040	M32 x 1.5	45	52	11
83041	M35 x 1.5	47	55	11
83042	M36 x 1.5	48	55	11
83043	M48 x 1.5	67	75	13
83044	M70 x 1.5	90	100	14

#### Extracting disk

for ultra live centers

type RN/RNC/RNA/RNW

cat. no.	size	MK	D1	D2	h
83031	3	3	28	80	4
83032	3	4	38	80	5
83033	3	5	49	80	5
83034	4	4	38	100	5
83035	4	5	49	100	5
83036	5	5	49	120	5
83037	5	6	70	120	6
83038	6	6	70	140	6

#### Extracting nut type DIN 807

for dead centers and center pins

cat. no.	MK	D1	D2	s	h
92999	1	M16 x 1.5	23	24	12
93000	2	M22 x 1.5	30	32	15.5
93001	3	M27 x 1.5	39	41	17.5
93002	4	M36 x 1.5	53	55	21
93003	5	M48 x 1.5	67	75	23
93004	6	M68 x 1.5	90	100	25.5

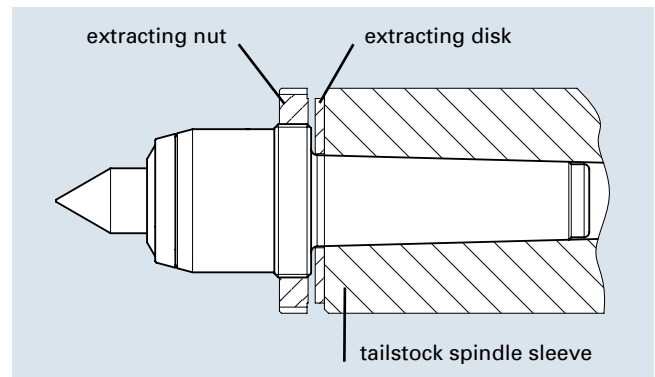

#### Type DIN 1804 h

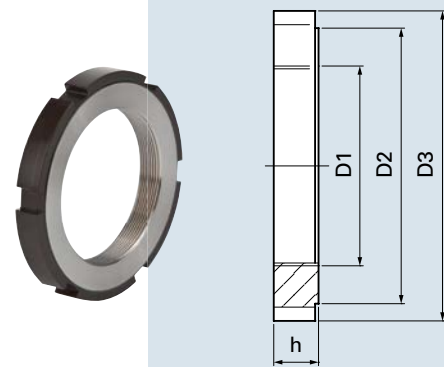

#### Extracting disk

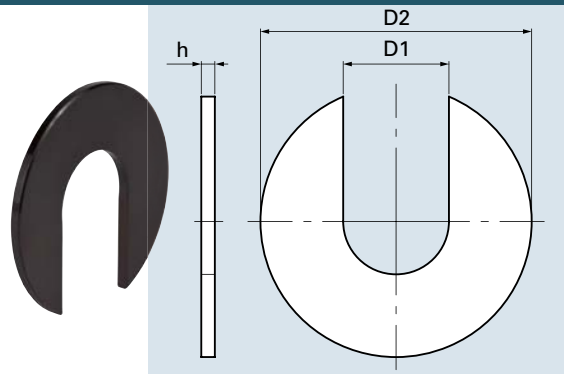

#### Type DIN 807

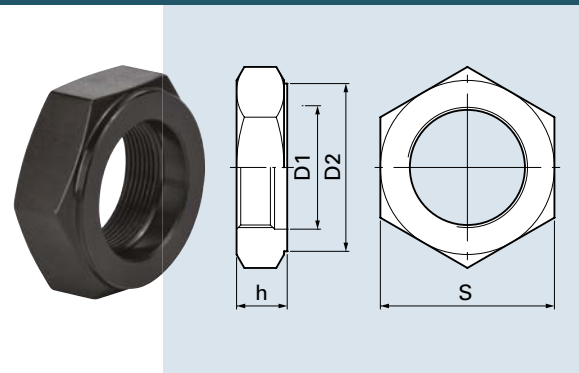

## Custom-Made Designs

Upon customer's request we design and produce center pins for any kind of clamping device.

Made of **tool steel** or with **carbide insert**, standard or customized tapers. You advise us of your requirements and we will submit a non-binding offer to you with best possible delivery time.

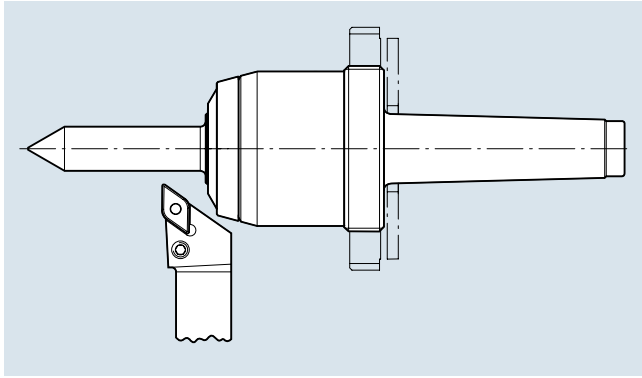

Type RN special 4881-00-02



with extra long spindle for more workspace for tools

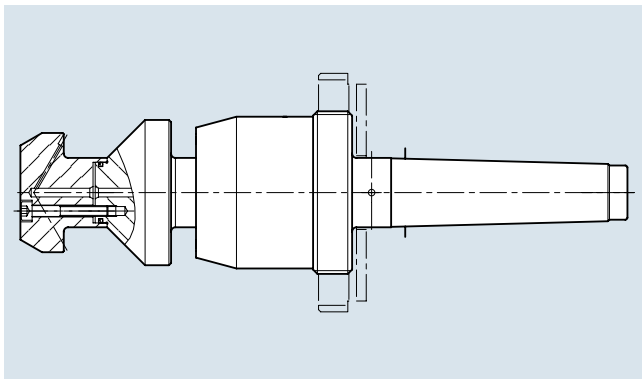

Type RN special 4428-00



with air-trough attachment unit/for chip cleanup on work piece

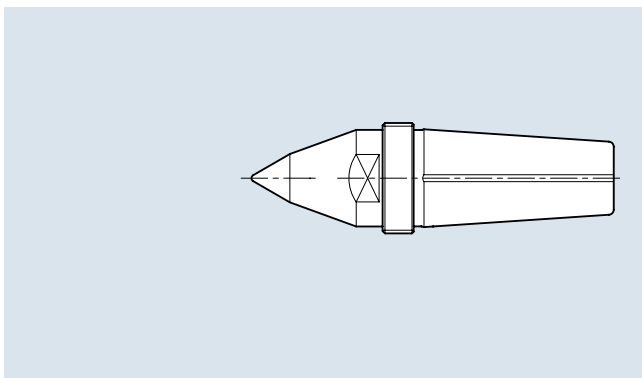

Dead center special SK1703-173



with taper 1:7.5 for spindle sleeves mounted in e.g. EMAG machine tools.

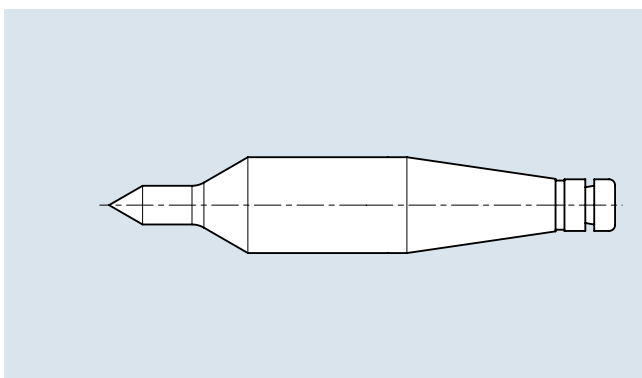

Dead center 91812



with short taper SK30 various types for MAG/ Böhlinger and INDEX machines